

Huitt-Zollars, Inc.

East Fairview Drainage Study

Town of Fairview

Prepared for:

Town of Fairview

372 Town Place
Fairview, TX 75069

Prepared by:

Huitt-Zollars, Inc.

1717 McKinney Avenue, Suite 1400
Dallas, TX 75202
Firm Registration No. F-761

T (214) 871-3311
F (214) 871-0757

www.huitt-zollars.com

October 08, 2020



A handwritten signature in black ink, appearing to read "Hamilton Dallagasperina", written over a horizontal line.

Table of Contents

Introduction 1

Approach 1

Methodology 3

Sensitivity Analysis 3

 Pre-development 3

 Fully Developed 5

Mitigation Alternatives..... 10

 Regional Detention 10

 Flood Protection Levee..... 17

 Streambank Erosion Control 25

Floodplain Mapping 43

Conclusion 45

Appendices

- Appendix A
 Effective Drainage Area Map
- Appendix B
 Lag Time Calculations
- Appendix C
 Effective Topographic Workmap

Introduction

In recent years, residents in the east part of Fairview have been reporting an increase in flooding events within the Sloan Creek watershed. According to long-time residents living on properties backing up to Sloan Creek, the main banks have overtopped with more frequency in the past 5 years, causing backyards and secondary buildings – and in some cases houses which are located within the FEMA 100-year floodplain – to flood more often. Streambank erosion is another issue affecting properties at various locations along Sloan Creek. Erosion has caused both loss of land and trees. The increase in flooding can be attributed both to the increased rainfall amounts seen in this region in the past 5 years and as a result of the gradual incremental runoff due to new developments over the years within the Sloan Creek watershed.

This Drainage Study has been prepared to offer the Town of Fairview and its residents an assessment of the issues and potential alternatives to provide flood protection to flood prone areas and options to protect the eroded streambank sections of Sloan Creek. In 2016, Huitt-Zollars developed a Master Drainage Plan for the Commercial Planned Development District (CPDD), which established guidelines for development that would not adversely impact the eastern part of Fairview, downstream from the CPDD. This Study included field evaluations along the majority of the length of Sloan Creek, and extensive hydrologic analysis of the upper portion of the Sloan Creek watershed. In 2019, Huitt-Zollars finished a LOMR, which re-mapped the FEMA floodplain along Sloan Creek and some of its tributaries, from U.S Highway 75 to its confluence with Wilson Creek. Armed with the knowledge and insight gained in these two studies and utilizing the current FEMA effective hydrologic and hydraulic models, Huitt-Zollars has further investigated options to reduce flooding and protect eroded streambanks along Sloan Creek. This Study describes the results of the hydrologic modeling performed for different scenarios, aiming to arrive at the most viable and cost-effective solutions to the drainage issues affecting residents in eastern Fairview.

Approach

The Sloan Creek watershed within Fairview is near full development. It is estimated that the total area of undeveloped/underdeveloped land in the area of Fairview east of Highway 5 that could potentially be developed is 412 acres. Of this, approximately 320 acres eventually drain to Sloan Creek and the remaining 92 acres eventually drain to Wilson Creek. Figure 1 shows the locations and acreages of each site within and outside the Sloan Creek watershed east of Highway 5. In an effort to prevent adverse drainage impacts to residents in the eastern part of the town, further detailed hydrologic analysis and modeling was necessary to determine how the watershed will respond under different scenarios. To put things in perspective it is also important to understand the magnitude of peak discharge increase from the time the town was completely undeveloped to the present time. With that in mind, a high-level hydrologic analysis was performed comparing effective peak discharges at various locations between Highway 5 and Wilson Creek to the peak discharges from a hydrologic model that assumed undeveloped conditions for the entire town. The peak discharge differences provide a better feel for the impact of development over the town's history, from the completely undeveloped period to the current nearly full development condition.

East Fairview Drainage Study

A sensitivity analysis was necessary to understand the impact of requiring on-site detention for all future development within Fairview. This analysis answers the question of whether or not at this point in the town's development history, requiring on-site detention for the remaining 320 acres in the Sloan Creek watershed would result in a positive impact to the eastern section of the town. The answer to this question could be used to consider the idea of modifying the town's drainage ordinance to require on-site detention for all future development. It is worth noting that detention is currently required under certain circumstances, which normally exclude low-density residential developments.

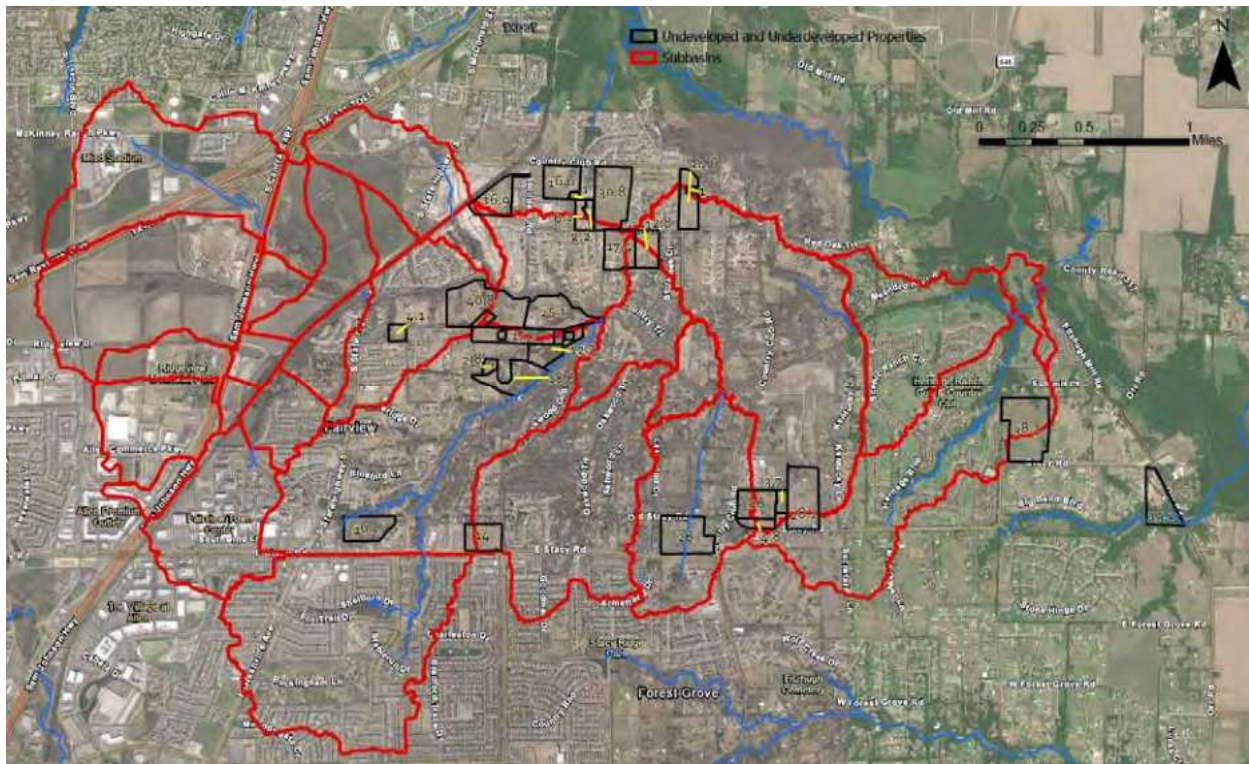

Figure 1 – Undeveloped and underdeveloped sites east of Highway 5

In addition to assessing potential impacts from future development and providing consideration on how best to mitigate that potential, this study also assesses the potential of mitigating existing drainage issues. In order to provide mitigation to the current drainage issues, an analysis of the impact of a large regional detention facility to the downstream eastern portion of the watershed was conducted as part of this study. As opposed to multiple small on-site detention facilities, a large facility has the potential to provide a significant impact due both to its ability to store larger volumes and to influence timing of peak discharge within the watershed. This study aims to compare these different scenarios to understand how the watershed will respond at different locations along Sloan Creek and what the impacts are to the eastern portion of the town, with the objective of finding viable alternatives to reduce flooding events.

Another aspect of mitigation involves looking at potential improvements that could be made along Sloan Creek to protect the homes along Camino Real from the more frequent flooding events that have recently taken place. The potential improvements need to be verified through a hydraulic model to verify a zero rise in Base Flood Elevation (BFE) through the FEMA Zone AE with regulatory Floodway section of Sloan Creek. Finally, to address streambank erosion the first step is to understand the causes of erosion so that an adequate solution can be achieved. Understanding the causes of erosion involves field evaluations, as well as a desktop analysis of the effective hydraulic models. An in depth analysis of the hydraulic parameters can offer insight

into the causes of erosion and help to achieve ways to both protect existing banks and prevent future erosion, as well as predicting locations that are susceptible to erosion.

A conceptual cost estimate is provided for potential solutions to streambank erosion and flood protection to provide City government and citizens with an understanding of the magnitude of cost associated with the potential solutions.

Methodology

The software and methods utilized in this study are consistent with the previous studies developed by Huitt-Zollars for the Town of Fairview, namely the 2016 Master Drainage Plan for the CPDD, the hydrologic and hydraulic analysis of Sloan Creek and some of its tributaries in support of the 2018 LOMR, and the 2020 Drainage Downstream Assessment for the Molodow and Collinwood sites. The effective hydrologic and hydraulic models from these previous studies were utilized where applicable to ensure continuity and consistency with previous studies and to reduce the effort related to modeling. As with the previous studies, HEC-HMS and HEC-RAS are the software of choice for hydrologic and hydraulic analysis and modeling, respectively. The NRCS Curve Number method was utilized to generate peak discharges, using current soils and land use data, and future land use data based on the Town's future Land Use Plan.

Sensitivity Analysis

Pre-Development

Apart from the reports from long-time residents and historical rainfall and gage records, drainage study numbers tell the story and provide the explanation to the amount, magnitude and frequency of flooding events. It is important to have a good feel for what drainage study numbers represent and how they translate into real-life situations as these relate to drainage. With this mindset, using the effective FEMA hydrologic model Huitt-Zollars created a pre-developed conditions model for the Town of Fairview to estimate what were the peak discharges prior to any development having occurred. Curve Numbers were estimated based on undeveloped land use consisting mostly of pasture, grass land, or range in good condition. Curve numbers are a key hydrologic parameter influencing peak discharge calculations. They are calculated based on a combination of the specific soil type and land use for a particular area. The higher the Curve Number typically means the soil has a reduced capacity to absorb runoff and/or the surface is less permeable. Table 1 shows a comparison between pre-development and existing Curve Numbers for the 28 sub-basins comprising the Sloan Creek watershed. Sub-basin delineation is depicted in the Drainage Area Map in Appendix A. Since the soils are essentially unchanged from the pre-development period to the present time, the change in land cover is what has caused the increase in Curve Numbers. As expected, Curve Numbers for pre-development conditions are lower than Curve Numbers for existing conditions. With most of the land use in Fairview consisting of low-density residential development, the increase in Curve Number is not as drastic as it would be in most cities where moderate and high-density development make up for the majority of use in the land.

East Fairview Drainage Study

Existing		Pre-Development	
Subbasin	Curve Number	Subbasin	Curve Number
1	88.0	1	78.8
2	86.2	2	78.3
3	85.0	3	77.5
4	85.9	4	77.3
5	91.2	5	78.9
6	88.2	6	79.5
7	85.6	7	78.7
8	85.6	8	79.1
9	86.9	9	79.1
10	84.8	10	78.3
11	87.1	11	79.1
12	78.5	12	75.5
13	85.3	13	78.9
14	86.0	14	76.6
15	92.9	15	79.5
16	79.2	16	75.2
17	84.4	17	76.5
18	83.0	18	76.3
19	91.3	19	79.6
20	79.9	20	72.7
21	81.3	21	76.1
22	84.2	22	78.4
23	80.0	23	76.2
24	82.4	24	78.4
25	79.9	25	75.1
26	84.1	26	74.6
27	84.7	27	77.7
28	83.7	28	75.6

Table 1 – Existing and Pre-Development CN

Peak discharges for the 100-year frequency event were calculated at different locations along Sloan Creek and compared between pre-development and existing conditions. Table 2 displays the results, which show increases in the range of 10% to 12%. These discharge increases represent all development that has occurred within Fairview throughout its history.

East Fairview Drainage Study

Junction	Location	Discharge (cfs)		% Increase
		Pre-Development	Existing	
Outlet	Wilson Creek confluence	12,640	14,012	10.85%
J26	East Boundary Heritage Ranch	12,689	14,024	10.52%
J25B	West Boundary Heritage Ranch	11,902	13,101	10.07%
J25A	Country Club Drive	10,687	11,897	11.32%
J23	Between Hackberry Dr and Cottonwood Pl	10,919	12,114	10.94%
J21	Just north of Maple Ln	10,194	11,346	11.30%
J18	West end of Country Trail	8,809	9,849	11.81%
J16	Barksdale Creek	5,677	6,347	11.80%
J17	Pond View Ln & Sloan Ck. Pkwy	4553	5,108	12.19%

Table 2 – Existing and Pre-Development 100-year Peak Discharge Comparison

Fully Developed

A sensitivity analysis has been conducted to determine the impacts of requiring on-site detention for the remaining undeveloped or underdeveloped 320 acres that drain either directly or indirectly to Sloan Creek. The effective hydrologic model for the Sloan Creek watershed consisting of 28 sub-basins was used to create a modified version further breaking down smaller sub-basins where the on-site detention facilities would be located. The Drainage Area Map in the next page shows the original 28 sub-basins and the smaller sub-basins created to account for on-site detention for the different sites. For instance, sub-basin 18B was carved out of the original sub-basin 18 to represent the 16.2-acre site near Stacy Road, which would have its own on-site detention upon development. A total of 12 smaller sub-basins were defined combining some of the smaller sites into one larger site for the purposes of this analysis. The Drainage Area Map also shows the locations of junctions along Sloan Creek where peak discharges are calculated and compared so the impact of on-site detention for future developments can be examined. Curve Numbers were calculated for the 12 smaller sub-basins and adjusted for the affected original sub-basins. Table 3 shows the Curve Numbers for the affected sub-basins for existing and proposed conditions.

CURVE NUMBER		
Subbasin	Existing	Proposed
17	84.4	84.5
17A	70.9	74.1
18	83.0	83.2
18A	67.1	69.5
18B	77.7	82.2
20	79.9	80.7
20A	84.0	84.0
20B	68.2	70.5
21	81.3	81.5
21A	78.4	81.3
22	84.2	84.2
22A	80.0	84.1
24	82.4	82.4
24A	80.0	81.0
25	79.9	79.9
25A	80.1	83.8
25B	79.3	79.8
25C	79.0	80.0
27	84.7	84.9
27A	76.5	79.0

Table 3 – Existing and Proposed CN

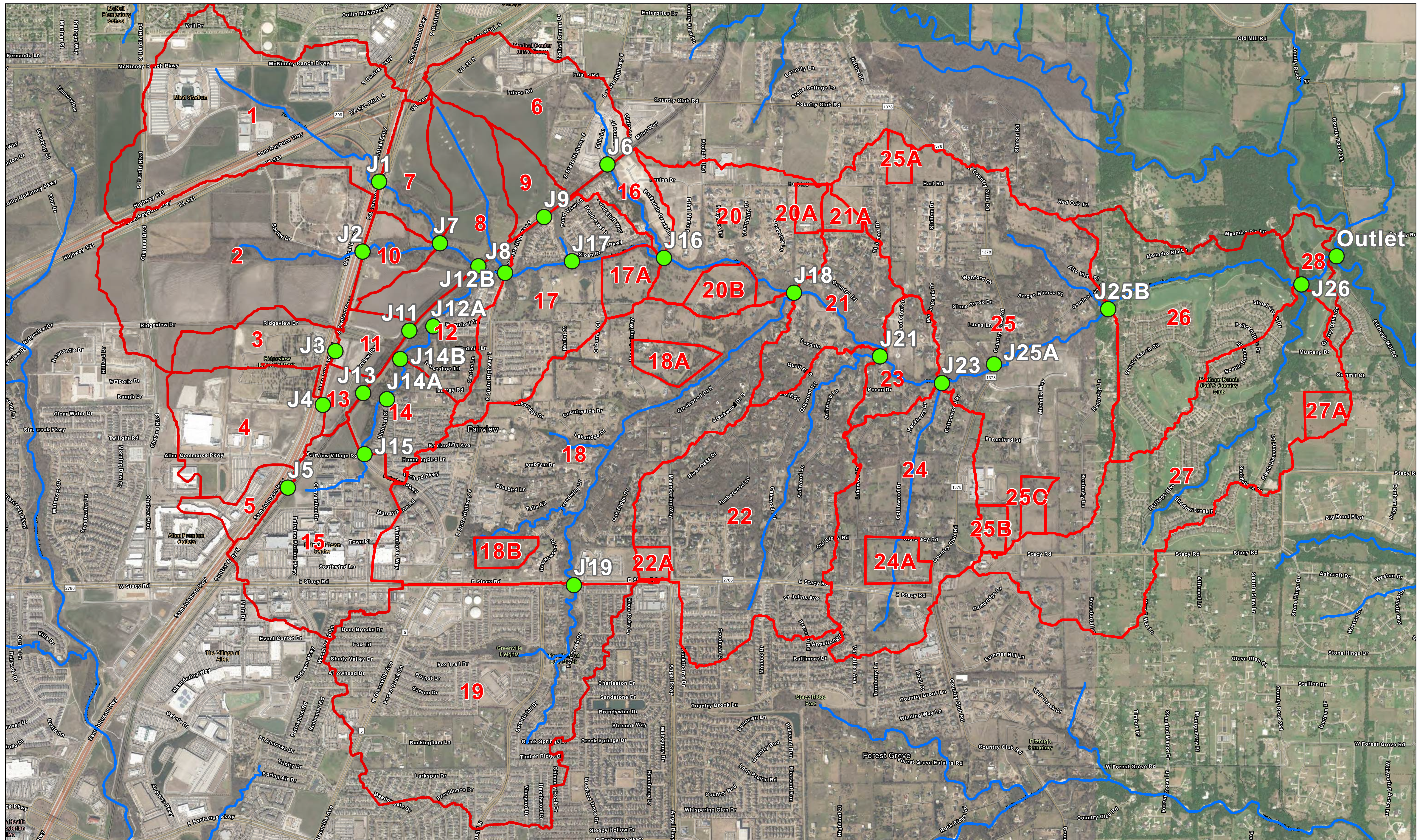

Legend
● Junctions Subbasins

Drainage Area Map

0 500 1,000 2,000 3,000 4,000 Feet

HUITT-ZOLIARS



East Fairview Drainage Study

The smaller sub-basins had a more significant increase in Curve Number values due to the change in land use. The larger sub-basins had a smaller change attributed to the removal of the undeveloped sites from its overall area. Lag times for the larger sub-basins generally stayed the same. Lag times for the smaller sub-basins with on-site detention were assumed to be in the range of 10 minutes to 15 minutes based on site acreage, for the purposes of this sensitivity analysis. These parameters along with the acreage for all affected sub-basins were entered into HEC-HMS to create hydrologic models covering different scenarios and conditions:

1. Existing Conditions
2. Developed Conditions
3. Developed Conditions Full On-site Detention
4. Developed Conditions Partial Detention 1
5. Developed Conditions Partial Detention 2
6. Developed Conditions Partial Detention 3
7. Developed Conditions Partial Detention 4

The existing conditions model simply reflects the current watershed condition, including undeveloped conditions for the 320 acres. The developed conditions model assumes the 320 acres are developed, but without on-site detention. The Full On-site Detention model accounts for a total 12 detention facilities to detain on-site runoff from the 320 acres. The four Partial Detention models only account for a reduced number of on-site detention facilities at specific locations. These different scenarios were modeled with the goal of determining the optimal number and location of detention facilities that would result in the greatest benefit to Sloan Creek, namely the greatest reduction in peak discharge at the various analyzed locations along the stream. The model called Partial Detention 1 assumes the sites on sub-basins 25A, 25B, 25C, and 27A, all located in the eastern part of the watershed, do not have on-site detention. The model called Partial Detention 2 assumes no detention is provided to the sites on sub-basins 21A, 22A, 24A, 25A, 25B, 25C, and 27A, located in the eastern and center part of the watershed. The Partial Detention 3 model assumes no detention is provided to the sites on sub-basins 17A, 18A, 18B, 20A and 20B, located west of the center of the watershed. The Partial Detention 4 model assumes no detention is provided to the sites on sub-basins 17A, 18A, 18B, 20A, 20B, 21A, 22A, and 24A, located in the center and west of the center of the watershed. The criteria used for detention design was to detain the proposed development discharges and release them at pre-development rates or lower. Tables 4, 5, 6, 7, and 8 display the results of the different model runs, comparing peak 100-year discharges for existing, developed (without detention), and developed with detention scenarios.

Junction	Location	Discharge (cfs)			Discharge Diff. (cfs)		% Discharge Diff.	
		Existing	Developed	Detention	Det - Dev	Det - Exis	Det - Dev	Det - Exis
Outlet	Wilson Creek confluence	13,994	14,009	14,055	46	61	0.33%	0.44%
J26	East Boundary Heritage Ranch	14,028	14,042	14,067	25	39	0.18%	0.28%
J25B	West Boundary Heritage Ranch	13,094	13,101	13,144	43	50	0.33%	0.38%
J25A	Country Club Drive	12,019	12,032	12,034	2	15	0.02%	0.12%
J23	Between Hackberry and Cottonwood	12,138	12,147	12,143	-4	5	-0.03%	0.04%
J21	Just north of Maple Ln	11,359	11,361	11,360	-1	1	-0.01%	0.01%
J18	West end of Country Trail	9,812	9,834	9,854	20	42	0.20%	0.43%
J16	Barksdale Creek	6,370	6,375	6,373	-2	3	-0.03%	0.05%
J17	Pond View Ln & Sloan Ck. Pkwy	5113	5113	5113	0	0	0.00%	0.00%

Table 4 – Existing, Developed, and Developed Full On-Site Detention 100-yr Discharges

East Fairview Drainage Study

Junction	Location	Discharge (cfs)			Discharge Diff. (cfs)		% Discharge Diff.	
		Existing	Developed	Detention	Det - Dev	Det - Exis	Det - Dev	Det - Exis
Outlet	Wilson Creek confluence	13,994	14,009	14,004	-5	10	-0.04%	0.07%
J26	East Boundary Heriate Ranch	14,028	14,042	14,042	0	14	0.00%	0.10%
J25B	West Boundary Heritage Ranch	13,094	13,101	13,122	21	28	0.16%	0.21%
J25A	Country Club Drive	12,019	12,032	12,018	-14	-1	-0.12%	-0.01%
J23	Between Hackberry and Cottonwood	12,138	12,147	12,143	-4	5	-0.03%	0.04%
J21	Just north of Maple Ln	11,359	11,361	11,360	-1	1	-0.01%	0.01%
J18	West end of Country Trail	9,812	9,834	9,854	20	42	0.20%	0.43%
J16	Barksdale Creek	6,370	6,373	6,373	0	3	0.00%	0.05%
J17	Pond View Ln & Sloan Ck. Pkwy	5113	5113	5113	0	0	0.00%	0.00%

Table 5 – Existing, Developed, and Developed Partial Detention 1 100-yr Discharges

Junction	Location	Discharge (cfs)			Discharge Diff. (cfs)		% Discharge Diff.	
		Existing	Developed	Detention	Det - Dev	Det - Exis	Det - Dev	Det - Exis
Outlet	Wilson Creek confluence	13,994	14,009	13,999	-10	5	-0.07%	0.04%
J26	East Boundary Heriate Ranch	14,028	14,042	14,035	-7	7	-0.05%	0.05%
J25B	West Boundary Heritage Ranch	13,094	13,101	13,110	9	16	0.07%	0.12%
J25A	Country Club Drive	12,019	12,032	12,014	-18	-5	-0.15%	-0.04%
J23	Between Hackberry and Cottonwood	12,138	12,147	12,136	-11	-2	-0.09%	-0.02%
J21	Just north of Maple Ln	11,359	11,361	11,365	4	6	0.04%	0.05%
J18	West end of Country Trail	9,812	9,834	9,854	20	42	0.20%	0.43%
J16	Barksdale Creek	6,370	6,373	6,373	0	3	0.00%	0.05%
J17	Pond View Ln & Sloan Ck. Pkwy	5113	5113	5113	0	0	0.00%	0.00%

Table 6 – Existing, Developed, and Developed Partial Detention 2 100-yr Discharges

Junction	Location	Discharge (cfs)			Discharge Diff. (cfs)		% Discharge Diff.	
		Existing	Developed	Detention	Det - Dev	Det - Exis	Det - Dev	Det - Exis
Outlet	Wilson Creek confluence	13,994	14,009	14,055	46	61	0.33%	0.44%
J26	East Boundary Heriate Ranch	14,028	14,042	14,063	21	35	0.15%	0.25%
J25B	West Boundary Heritage Ranch	13,094	13,101	13,119	18	25	0.14%	0.19%
J25A	Country Club Drive	12,019	12,032	12,042	10	23	0.08%	0.19%
J23	Between Hackberry and Cottonwood	12,138	12,147	12,154	7	16	0.06%	0.13%
J21	Just north of Maple Ln	11,359	11,361	11,356	-5	-3	-0.04%	-0.03%
J18	West end of Country Trail	9,812	9,834	9,834	0	22	0.00%	0.22%
J16	Barksdale Creek	6,370	6,373	6,375	2	5	0.03%	0.08%
J17	Pond View Ln & Sloan Ck. Pkwy	5113	5113	5113	0	0	0.00%	0.00%

Table 7 – Existing, Developed, and Developed Partial Detention 3 100-yr Discharges

Junction	Location	Discharge (cfs)			Discharge Diff. (cfs)		% Discharge Diff.	
		Existing	Developed	Detention	Det - Dev	Det - Exis	Det - Dev	Det - Exis
Outlet	Wilson Creek confluence	13,994	14,009	14,059	50	65	0.36%	0.46%
J26	East Boundary Heriate Ranch	14,028	14,042	14,067	25	39	0.18%	0.28%
J25B	West Boundary Heritage Ranch	13,094	13,101	13,122	21	28	0.16%	0.21%
J25A	Country Club Drive	12,019	12,032	12,047	15	28	0.12%	0.23%
J23	Between Hackberry and Cottonwood	12,138	12,147	12,147	0	9	0.00%	0.07%
J21	Just north of Maple Ln	11,359	11,361	11,361	0	2	0.00%	0.02%
J18	West end of Country Trail	9,812	9,834	9,834	0	22	0.00%	0.22%
J16	Barksdale Creek	6,370	6,373	6,375	2	5	0.03%	0.08%
J17	Pond View Ln & Sloan Ck. Pkwy	5113	5113	5113	0	0	0.00%	0.00%

Table 8 – Existing, Developed, and Developed Partial Detention 4 100-yr Discharges

Modeling results for the multiple scenarios show that the impact to Sloan Creek will be minimal if on-site detention is provided for all remaining undeveloped/underdeveloped sites or a combination of sites. For the Full On-Site Detention option (refer to Table 4) there are small

East Fairview Drainage Study

decreases in discharges at three locations and small increases in discharges at five locations when comparing the 'developed with detention' condition to the 'developed without detention condition'. An improvement can be seen when looking at the results for Table 5, which indicate decreases in discharges at four locations and increases in discharges at two locations. Additionally, the discharges are detained back to existing rates at J25A and J21. Partial Detention 2 is the optimal arrangement for quantity and location of on-site detention facilities. As seen in Table 6, discharges are expected to decrease at four locations and increase at three locations in the 'developed with detention' to 'developed without detention' comparison. Additionally, discharges are detained back to below existing rates at two locations.

The sensitivity analysis shows that providing on-site detention only at the sites located to the west of the center of the watershed (the upstream portion of the analyzed watershed) would result in the most reduction in peak discharges at some locations on Sloan Creek. However, there would also be increase in discharges at other locations. Both the increases and decreases in discharges are minimal, causing no adverse impact to Sloan Creek whether detention is provided or not. The main reason for the minimal impacts has to do with the size of the basins being detained (or not) being so small compared to the Sloan Creek basin. It is worth noting, that although the development of the 320 acres with or without detention will have no significant impact on Sloan Creek, a downstream drainage assessment for each site is needed in order to determine whether there will be adverse impacts to the properties downstream of the new developments, within the Zone of Influence of each development. The Zone of Influence (ZOI) is the downstream area subject to the drainage impact from the new development. The ZOI is typically defined based on the 10% rule, which states that the development is no longer expected to have a significant impact beyond the point where the site's acreage comprises 10% of the total downstream watershed area. The downstream assessment would not apply to the properties draining directly to Sloan Creek, but only to the sites that drain indirectly to Sloan Creek via other downstream properties. A drainage downstream assessment would be valuable to determine the need for detention and to assess the impacts to downstream properties within the Zone of Influence of each new site.

Mitigation Alternatives

Regional Detention

A regional detention facility has been evaluated as a potential alternative to mitigate for perceived increase in flooding events along the Sloan Creek floodplain in the east part of Fairview. Two possible sites were evaluated. The first site is located just west of Parkdale Drive in the south side of Sloan Creek. The second site is located approximately 1000 feet west of Parkdale Drive in the south side of Sloan Creek. The two sites are circled in red in Figure 2.



Figure 2 – Possible Regional Detention Facility Sites

In order to mitigate for downstream flooding the detention facility will need to provide a significant reduction in peak discharges in the downstream watershed. The concept of a ‘Zone of Influence’ also applies to a large detention facility. The areas immediately downstream of the facility tend to experience the greatest reduction in discharges. The reductions in discharge gradually attenuate further downstream. This was evidenced in the 2016 CPDD Master Drainage Plan Study, which showed that detaining flows in the commercial district had no significant impact in the far east section of the town. Along this line of thought, the location of the facility within the watershed is just as critical as its size to produce the desired results. The location of the two potential sites seems to be adequate if the goal is to reduce flows to mitigate for additional flooding in the center and eastern portions of the watershed.

A preliminary evaluation of the first site, which is also the smaller site (adjacent to Parkdale Drive), revealed the area is too small to provide the storage needed to make a significant impact downstream. A detention facility in the second site was then evaluated in more detail to determine if it is a viable alternative to mitigate for downstream increase in flooding along Sloan Creek. Two alternatives were evaluated for this site: one with an off-channel detention and one with an on-channel detention. In the off-channel alternative the design and model is based on

East Fairview Drainage Study

diverting part of the flows from the main creek to a detention facility adjacent to the creek, concurrently storing and releasing flows at a lower rate at an outfall structure back into the stream. In the on-channel alternative the design and model is based on either creating a dam in the main creek or diverting the main channel to a detention facility, concurrently storing and releasing flows at a lower rate at an outfall structure back into the stream. In the latter instance, the creek will flow through the detention facility while in the former instance, the creek will continue its course with only part of the flows being diverted through the detention facility.

On-Channel Detention

The detention site is located within sub-basin 20 as shown in the Drainage Area Map in the next page. Sub-basin 20 was divided in sub-basin 20A and sub-basin 20B to account for the detention facility. Curve Numbers for both sub-basins were re-calculated to be 75 for sub-basin 20A and 80 for sub-basin 20B, based on soil types and existing land use. Lag times were re-calculated to be 18 minutes and 24 minutes for sub-basin 20A and sub-basin 20B, respectively. Lag time calculations can be found in Appendix B. These parameters along with the area in square miles for each sub-basin were entered in HEC-HMS to create the model to route Sloan Creek flows through the detention facility. A preliminary site grading design was developed to determine Stage vs. Area data to calculate available storage. The design is based on re-routing the main stream to pass through the detention area, located adjacent and to the south of Sloan Creek, as opposed to creating a dam in the stream. Multiple configurations for an outfall structure consisting of a stepped weir were tested with the goal of maximizing available storage and reducing flows downstream.

The final configuration was a 40-ft long lower weir and a 100-ft long upper weir 10-ft higher than the lower weir. The total weir opening is 140 feet long. The structure is assumed to be of reinforced concrete and located in the middle of an earthen embankment. Due to lack of room to create a separate emergency spillway, the outfall structure would serve as both the principal and emergency spillway, passing up to the 100-year discharge. The 100-year water surface elevation in the lake will be the same or less than the effective 100-year elevation at Sloan Creek, causing no adverse impacts to properties adjacent to and upstream from the detention facility. Table 9 displays the results comparing undetained and detained 100-year flows.

Junction	On-Channel Detention Location	100 yr Discharge (cfs)		Decrease (cfs)	% Decrease
		Undetained	Detained		
Outlet	Wilson Creek confluence	13,994	13,731	263	1.9%
J26	East Boundary Heritage Ranch	14,028	13,804	224	1.6%
J25B	West Boundary Heritage Ranch	13,094	12,933	161	1.2%
J25A	Country Club Drive	12,019	11,518	501	4.2%
J23	Between Hackberry Dr and Cottonwood Pl	12,138	11,559	579	4.8%
J21	Just north of Maple Ln	11,359	10,837	522	4.6%
J18	West end of Country Trail	9,812	9,642	170	1.7%
J16	Barksdale Creek	6,370	6,355	15	0.2%

Table 9 – Discharge Comparison

Results show a significant decrease in peak 100-year discharges at all locations from Country Trail to Heritage Ranch. From a hydrology perspective, this is a viable alternative to alleviate flooding issues along Sloan Creek.

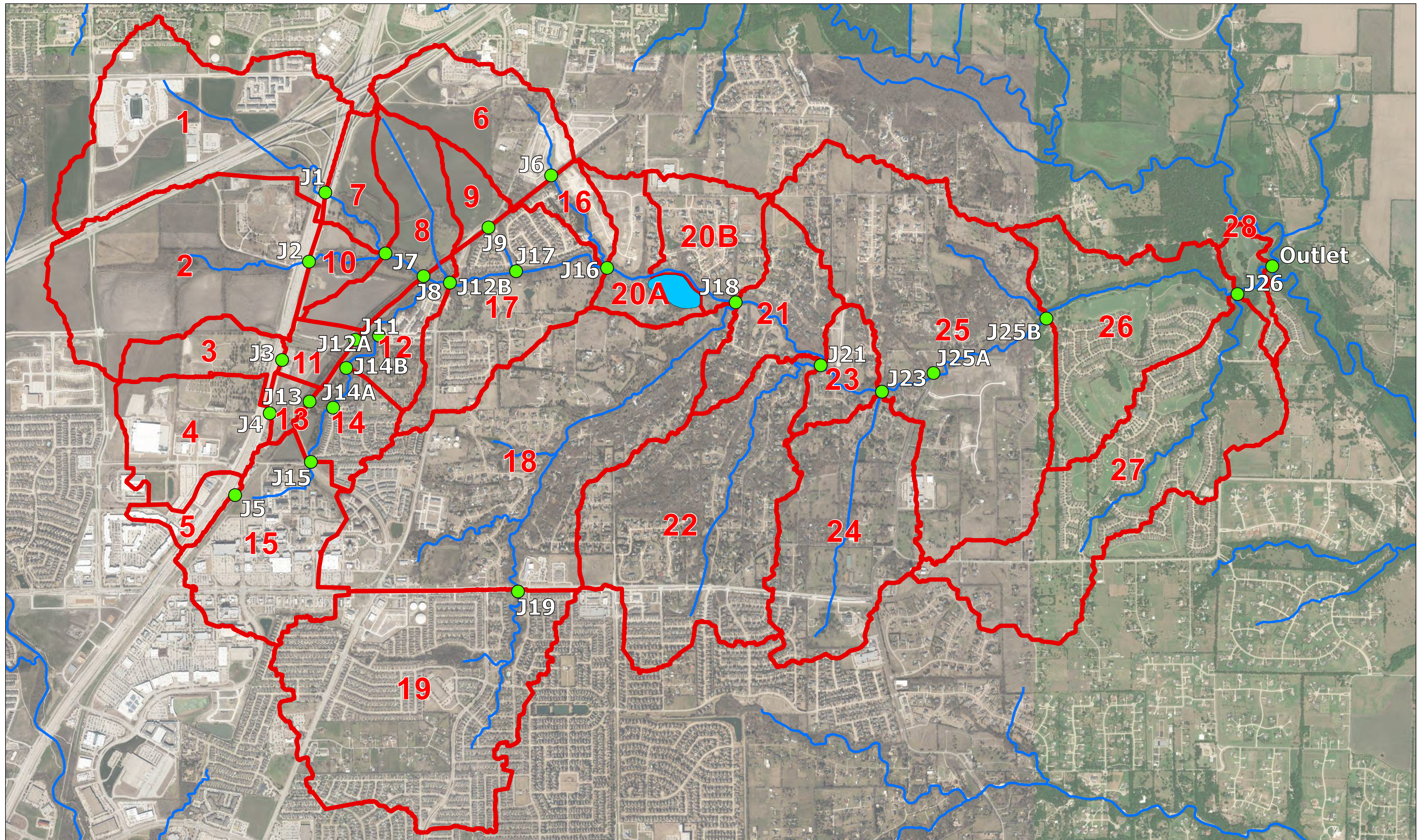

Legend
 - Subbasins - Regional Detention
 ● Junctions

Existing Drainage Area Map

0 500 1,000 2,000 3,000 4,000 Feet

HUITT-ZOLIARS



Off-Channel Detention

The design for the off-channel detention is based on diverting part of the flows from the main creek to a detention facility adjacent to it, and then releasing the flows at a slower rate back into the main channel. The diversion can be done by lowering the top of existing bank by an average of 4 feet, for a length of approximately 100 feet. This geometry was modeled as a lateral weir in HEC-RAS to generate an Inflow vs. Diversion function, which was then entered into HEC-HMS to model the diversion and route the diverted discharges through the detention area. Multiple configurations for an outfall structure consisting of a stepped weir were tested with the goal of maximizing available storage and reducing flows downstream.

The final configuration was a 20-ft long lower weir and a 30-ft long upper weir 6-ft higher than the lower weir. The total weir opening is 50 feet long. The structure is assumed to be of reinforced concrete and located in the middle of an earthen embankment. Due to lack of room to create a separate emergency spillway, the outfall structure would serve as both the principal and emergency spillway, passing up to the 100-year discharge. The 100-year water surface elevation in the lake will be the same or less than the effective 100-year elevation at Sloan Creek, causing no adverse impacts to properties adjacent to and upstream from the detention facility. Table 10 displays the results comparing undetained and detained 100-year flows.

Junction	Off-Channel Detention Location	100 yr Discharge (cfs)		Decrease (cfs)	% Decrease
		Undetained	Detained		
Outlet	Wilson Creek confluence	13,994	13,771	223	1.6%
J26	East Boundary Heritage Ranch	14,028	13,835	193	1.4%
J25B	West Boundary Heritage Ranch	13,094	12,888	206	1.6%
J25A	Country Club Drive	12,019	11,445	574	4.8%
J23	Between Hackberry Dr and Cottonwood Pl	12,138	11,542	596	4.9%
J21	Just north of Maple Ln	11,359	10,806	553	4.9%
J18	West end of Country Trail	9,812	9,569	243	2.5%
J16	Barksdale Creek	6,370	6,355	15	0.2%

Table 10 – Discharge Comparison

Results show a significant decrease in peak 100-year discharges at all locations from Country Trail to Heritage Ranch, similar to the on-channel detention alternative. The smaller weir size and limited grading on the main creek bank make the off-channel detention alternative the more viable option. Construction cost is expected to be lower, as well as the environmental impact. In the next page, a conceptual Grading Plan for the off-channel detention shows the grading limits, location of inflow weir, outfall control weir, and spillway conveying detained flows back to the main channel. In the following page, the outfall structure geometry is shown, as well as a profile through the dam embankment showing top of dam, spillway walls, wingwalls, and the location of the control weir. The facility can provide 64 ac-ft of storage for the 100-year storm event.

The dam would be considered small per TCEQ’s size classification. Due to the development downstream of the dam, the facility would be classified as high hazard. The embankment and outfall structure would also have to be adjusted to pass 75% of the Proposed Maximum Flood (PMF) to meet TCEQ dam safety requirements. The design would also need to meet NFIP regulations since it is within the FEMA floodplain. An environmental permit from the USACE might be necessary depending on the actual extent of the impact to the streambanks.

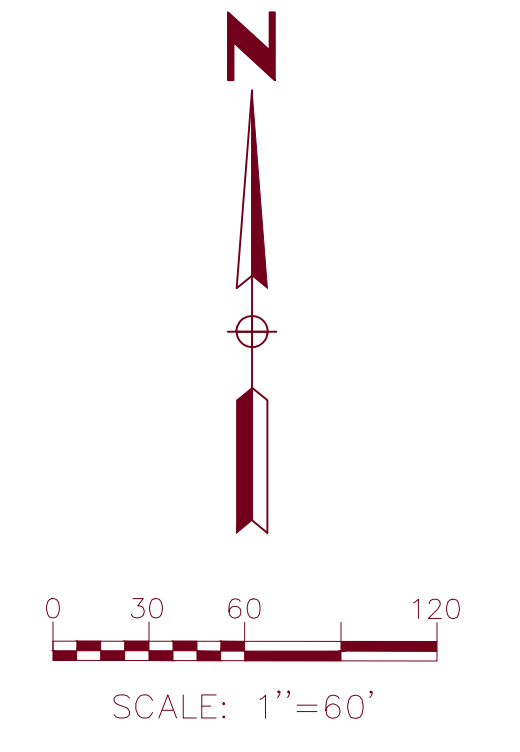

**EAST FAIRVIEW
REGIONAL DETENTION**

CONCEPTUAL GRADING PLAN

TOWN OF FAIRVIEW
COLLIN COUNTY, TEXAS

HUITT-ZOLLARS
Huitt-Zollars, Inc. Engineering / Surveying
 1717 McKinney Avenue, Suite 1400
 Dallas, Texas 75202-1236
 Firm no. F-761

SCALE AS NOTED	SHEET No.
DATE JUN 2020	

CAD FILE PATH:

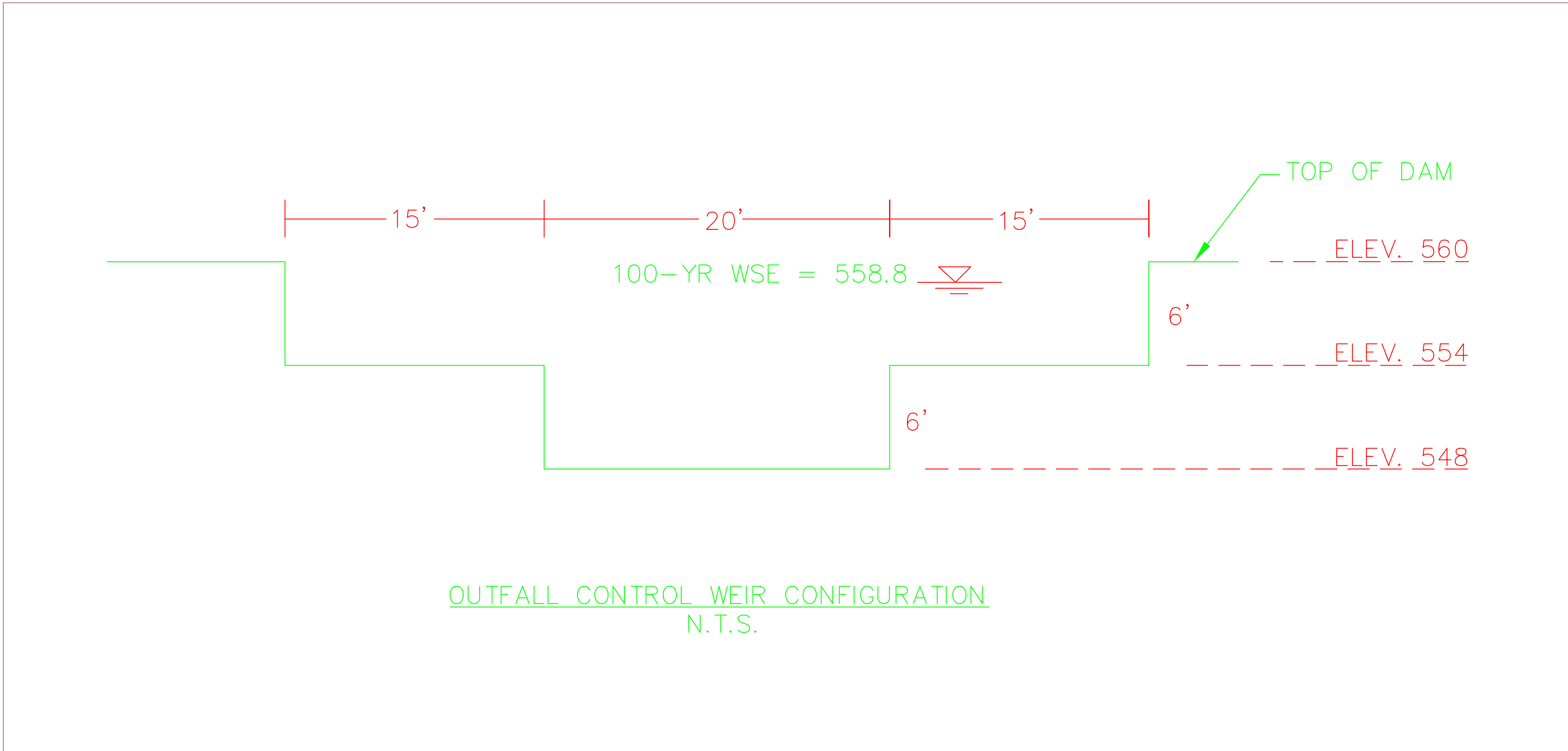
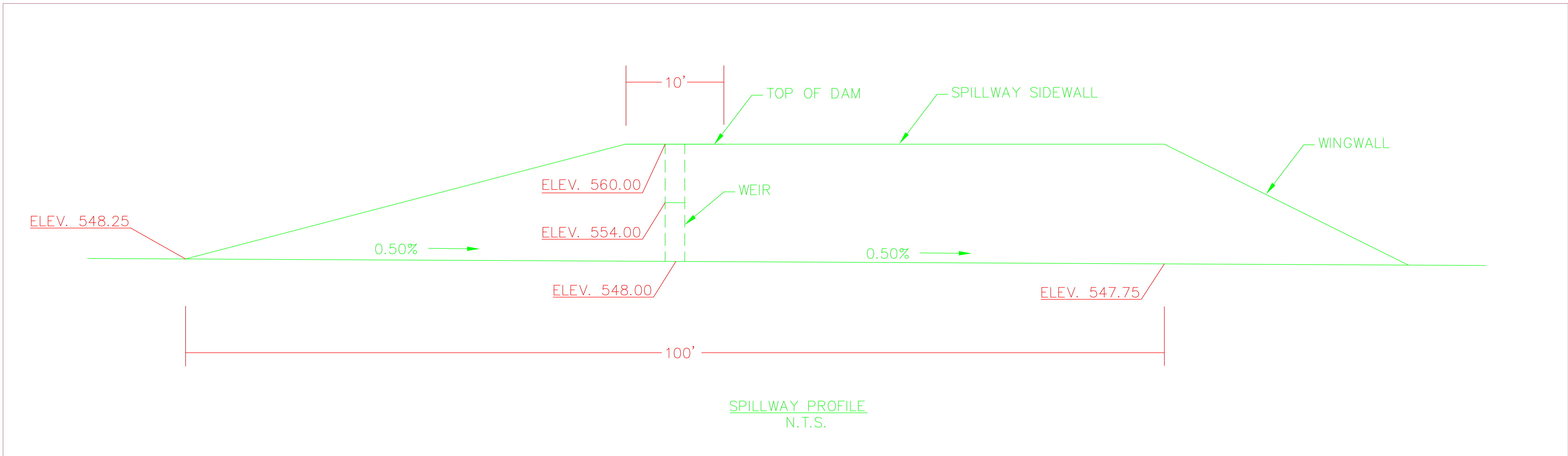

EAST FAIRVIEW REGIONAL DETENTION		
OUTFALL STRUCTURE DETAILS		
TOWN OF FAIRVIEW COLLIN COUNTY, TEXAS		
HUITT-ZOLIARS <small>Huitt-Zoliars, Inc. 1717 McKinney Avenue, Suite 1400 Dallas, Texas 75202-1236 Firm no. F-761</small>	SCALE AS NOTED DATE JUN 2020	SHEET No.

CAD FILE PATH:

East Fairview Drainage Study

The hydraulic model for Sloan Creek was run with the detained flows to determine the difference in water surface elevation 100-year profile along Sloan Creek, from just downstream of the detention outfall (cross-section 14558) to the location within Heritage Ranch where the backwater effects from Wilson Creek end (cross-section 3761). Table 11 shows the comparison results for water surface elevations for existing (undetained) and detained 100-year discharges.

X-Section	100-YR WS Elevation		Diff. Det-Exis. (ft)
	Existing (ft)	Detained (ft)	
14558	558.71	558.50	-0.2
14333	557.98	557.79	-0.2
14173	555.44	555.33	-0.1
14022	554.46	554.30	-0.2
13931	553.73	553.60	-0.1
13722	554.24	553.93	-0.3
13600	Park. Bridge	Park. Bridge	Park. Bridge
13592	553.64	553.32	-0.3
13448	552.98	552.69	-0.3
13336	552.18	551.90	-0.3
13079	552.60	552.30	-0.3
12912	551.20	550.92	-0.3
12688	550.72	550.42	-0.3
12510	550.53	550.22	-0.3
12247	549.40	549.08	-0.3
12003	549.45	549.12	-0.3
11727	548.71	548.46	-0.3
11497	548.96	548.64	-0.3
10968	546.49	546.35	-0.1
10778	545.35	545.38	0.0
10424	545.65	545.63	0.0
10096	545.65	545.63	0.0
9974	545.41	545.43	0.0
9537	545.29	545.32	0.0
9092	544.53	544.67	0.1
8930	544.50	544.65	0.1
8910	CC Bridge	CC Bridge	CC Bridge
8792	544.24	541.69	-2.5
8730	537.65	537.35	-0.3
8121	537.29	537.08	-0.2
7943	537.27	537.07	-0.2
7720	537.17	536.96	-0.2
7292	536.08	535.92	-0.2
6855	535.98	535.81	-0.2
6674	535.62	535.45	-0.2
6490	534.72	534.57	-0.1
6108	533.61	533.52	-0.1
5907	533.19	533.12	-0.1
5610	531.15	531.10	0.0
5437	530.14	530.09	0.0
5172	528.69	528.65	0.0
5097	528.48	528.44	0.0
4917	526.66	526.64	0.0
4732	525.18	525.14	0.0
4556	524.90	524.86	0.0
4378	524.71	524.67	0.0
4270	524.57	524.53	0.0
4129	524.39	524.35	0.0
3954	524.14	524.10	0.0
3761	523.98	523.94	0.0

Table 11 – Discharge Comparison

East Fairview Drainage Study

Cross-section locations can be seen in the Effective Topographic Work Map in Appendix C. Results from Table 11 show a decrease of up 0.3-ft in the 100-year water surface elevation along Sloan Creek in the Country Trail and Foxglen neighborhoods, an average decrease of 0.2-ft along Camino Real and Harper Landing, and no changes along Meandro Ria lane and Heritage Ranch. The decreases in water surface elevation are not very large, and will contribute to a small degree to alleviate flooding along Sloan Creek from approximately 1000 feet west of Parkdale Drive to Heritage Ranch. The off-channel regional detention facility based on the conceptual design and model will help to offset some of the increase in frequency of flooding observed in recent years, but its impact will not be large enough to remove homes out of the floodplain.

Flood Protection Levee

Another alternative to reduce flooding along the homes along Camino Real backing to Sloan Creek is the creation of a berm or levee blocking the water that overtops Sloan Creek to prevent it from reaching the homes. Some homes in this area are within the floodplain, while other homes are not in the floodplain but have sheds and other secondary structures within the floodplain. Hydraulic models were prepared, one with a 3-foot high levee and one with a 6-foot high levee. Both of them are effective in protecting the homes from flooding during the 100-year event. However, FEMA requires a minimum of 3-feet of freeboard to consider the earthen structure a levee and allow the area behind the levee to be removed from the floodplain in the Flood Insurance Rate Map. The 6-foot high levee provides the 3-feet of freeboard necessary for this. The lower levee will provide essentially the same level of protection as the higher levee for the 100-year event, with the advantage of a smaller structure that does not block as much the view from the homes to the creek and a smaller footprint resulting in less disturbance of land. The lower levee should provide a minimum of one-foot of freeboard. The obvious disadvantage is the fact that the effective floodplain will not be re-mapped to show homes or additional land being removed from the floodplain. The shorter levee will also not provide protection for discharges above the estimated 100-year event. For both options, an overflow channel parallel to the levee will need to be excavated to generate the soil material necessary to construct the levee and to maintain a zero rise in BFEs along the project length.

The lower levee design consists of a berm that is 3-feet wide at the top with 3(hor) to 1(ver) side slopes, a 6-foot bench, and an overflow channel trapezoidal in shape with a 10-foot minimum wide bottom and 4-feet in height. The total width for this design is 61 feet. The higher levee design has a 4-feet wide levee at the top, with 3:1 side slopes, a 6-foot bench, and a trapezoidal overflow channel that is 10-foot minimum wide at the bottom and 6-feet in height. The total width of this design is 94 feet. In the following two pages a layout of the levees and overflow channels are shown, followed by cross-section details for each levee. The overflow channel depth and width are greater in the eastern portion of the studied area in order to achieve a zero rise in BFEs. Both designs incorporate a number of 18-inch diameter drain pipes with a flap gate. The flap gate operates in one direction, allowing water behind the levee to drain toward the creek when the stage is lower, but preventing water from the floodplain to go behind the levee.

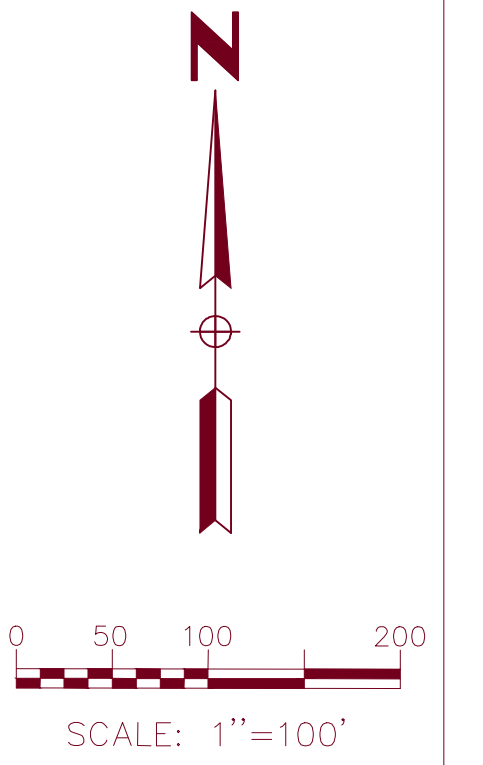
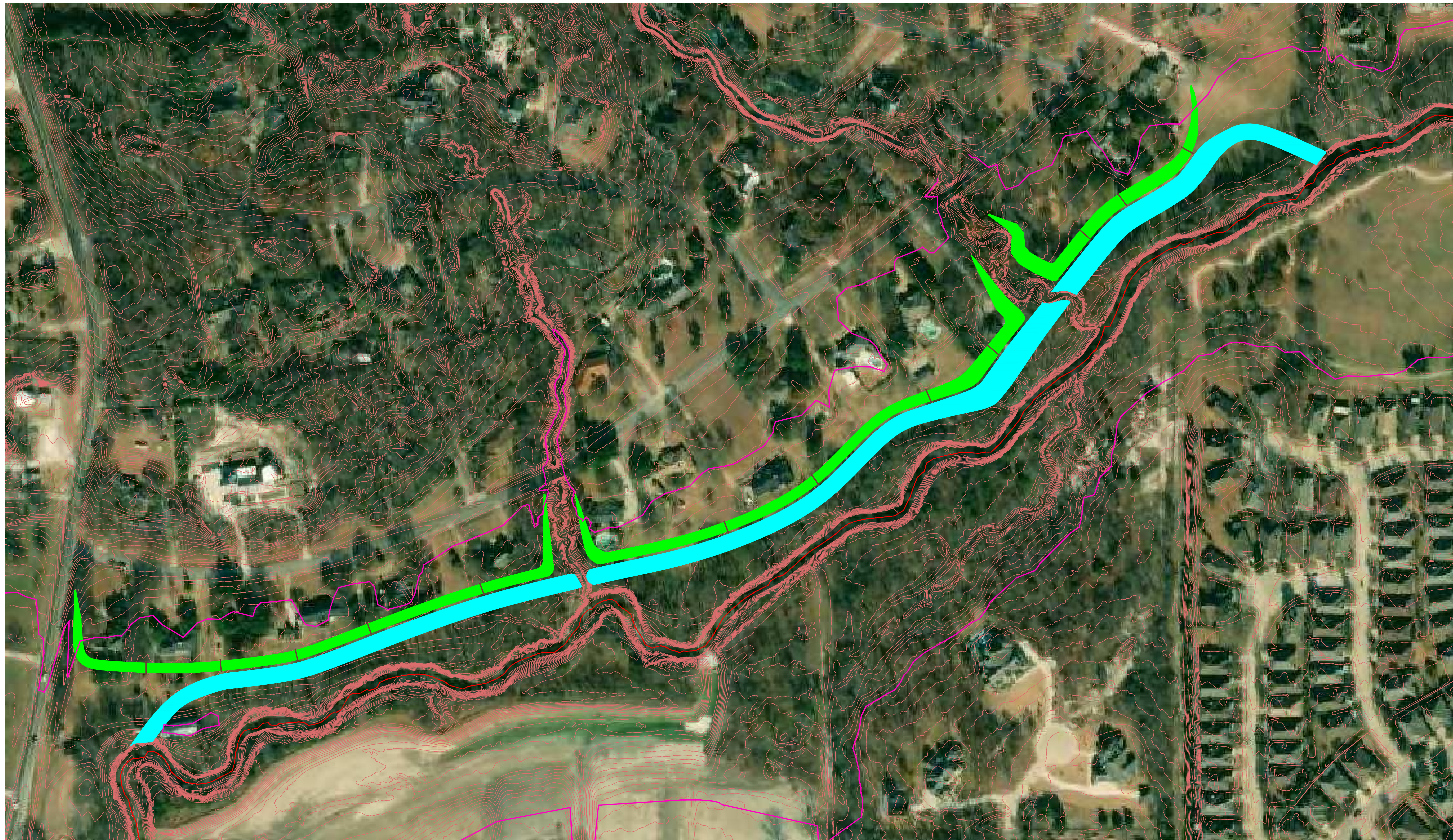

LEGEND

- SLOAN CREEK FLOWLINE
- FEMA 100-YR FLOODPLAIN
- 4-FT DEEP OVERFLOW CHANNEL
- 3-FT HIGH LEVEE
- 18-IN DRAIN & FLAP GATE

**EAST FAIRVIEW
MITIGATION ALTERNATIVES**

LOW LEVEE AND O/F CHANNEL

TOWN OF FAIRVIEW
COLLIN COUNTY, TEXAS

HUITT-ZOLIARS
Huitt-Zoliars, Inc. Engineering / Surveying
 1717 McKinney Avenue, Suite 1400
 Dallas, Texas 75202-1236
 Firm no. F-761

SCALE AS NOTED	SHEET No.
DATE JUN 2020	

CAD FILE PATH:

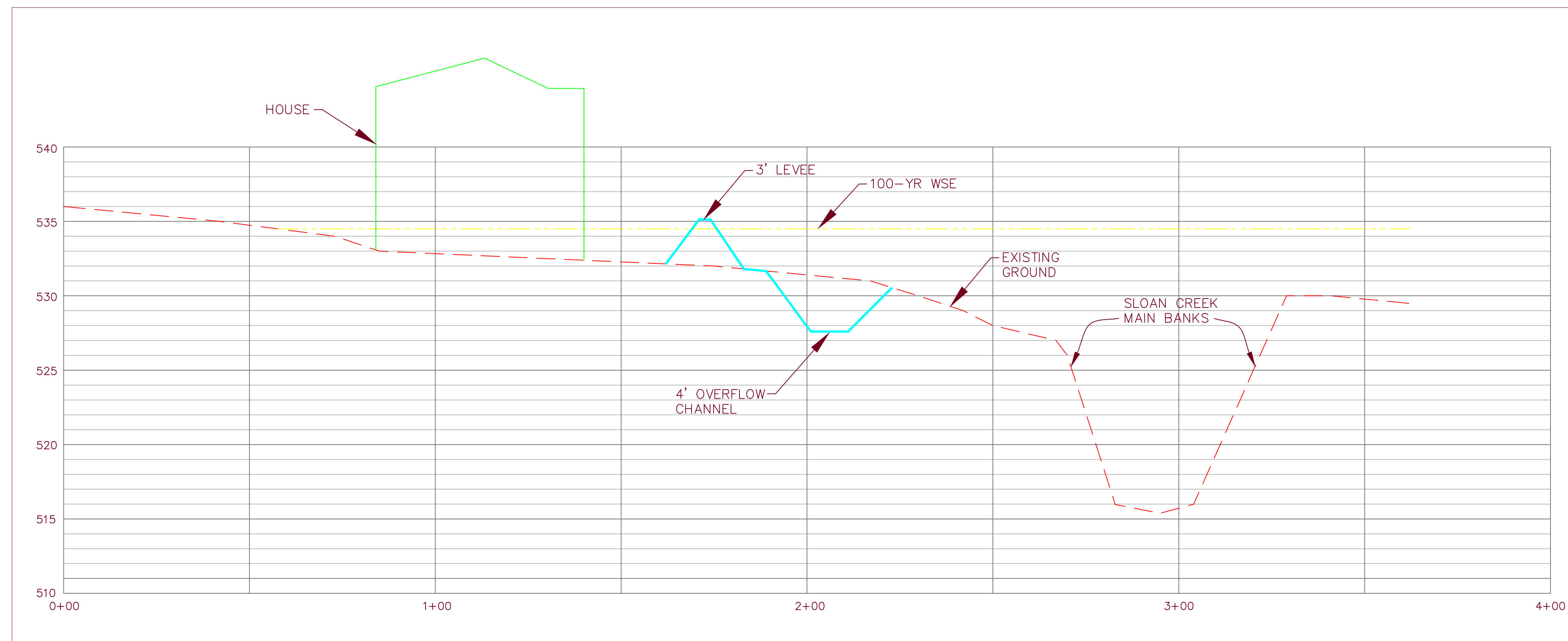

TYPICAL SECTION
SCALE: 1"=20' HOR; 1"=5' VER

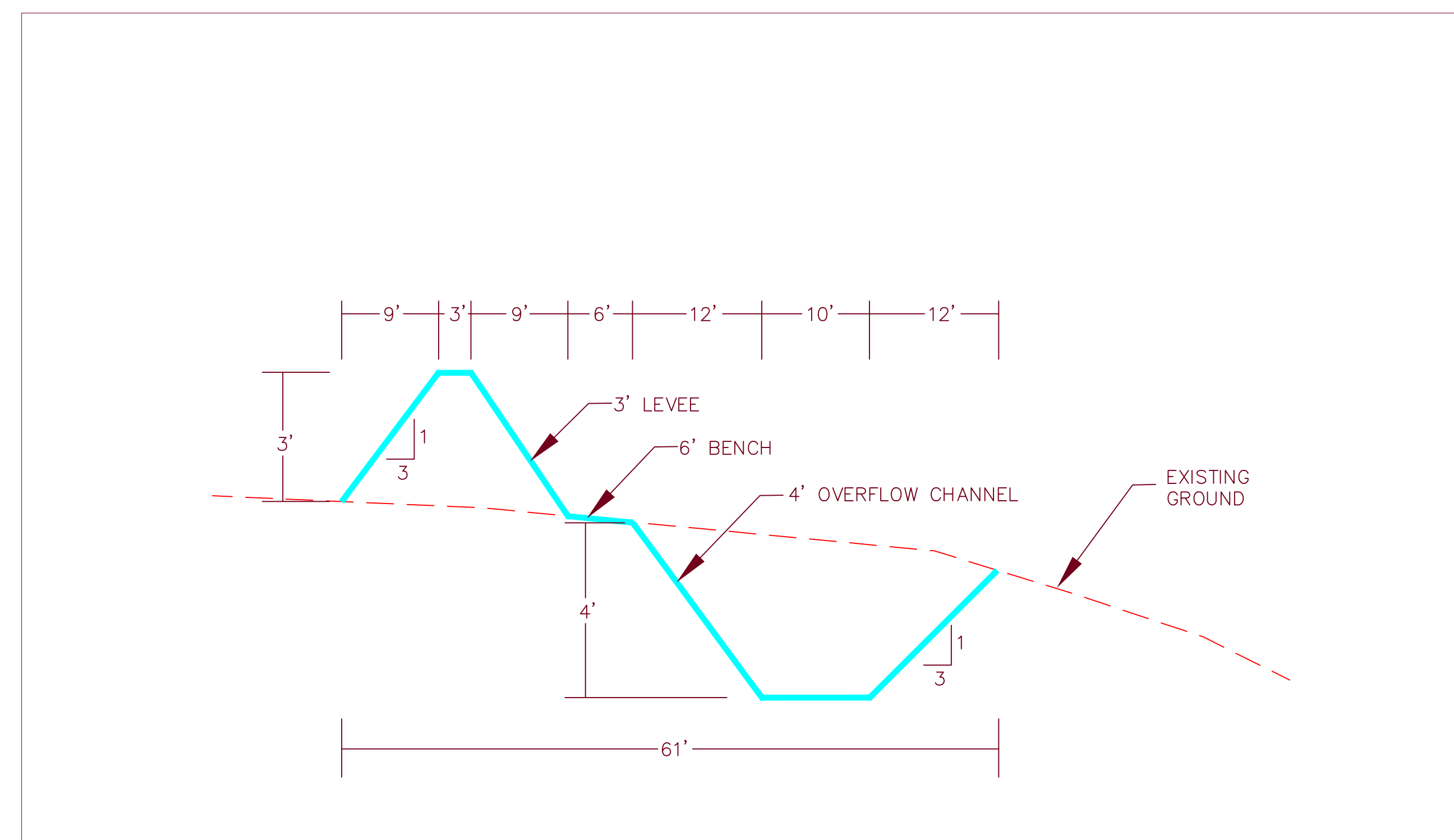

LEVEE AND OVERFLOW CHANNEL DETAIL
SCALE: 1"=10' HOR; 1"=2.5' VER

EAST FAIRVIEW MITIGATION ALTERNATIVES		
LEVEE & O/F CHANNEL DETAILS		
TOWN OF FAIRVIEW COLLIN COUNTY, TEXAS		
HUTT-ZOLIARS <small>Hutt-Zoliars, Inc. 1717 McKinney Avenue, Suite 1400 Dallas, Texas 75202-1236 Firm no. F-761</small>	SCALE AS NOTED DATE JUN 2020	SHEET No.

CAD FILE PATH:

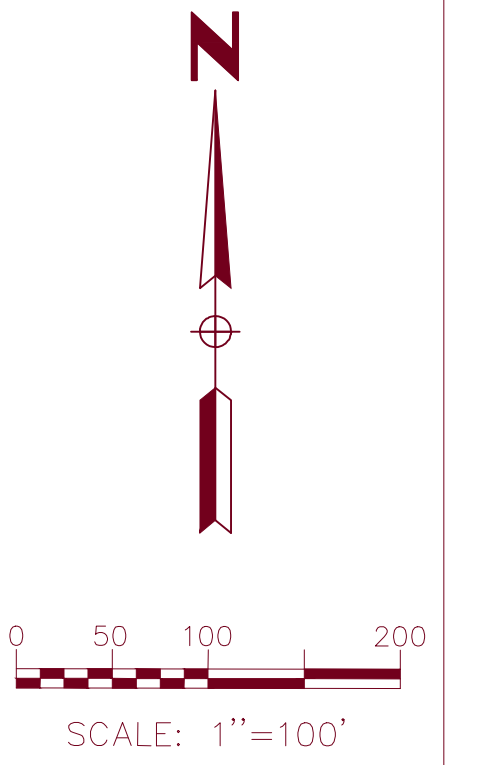
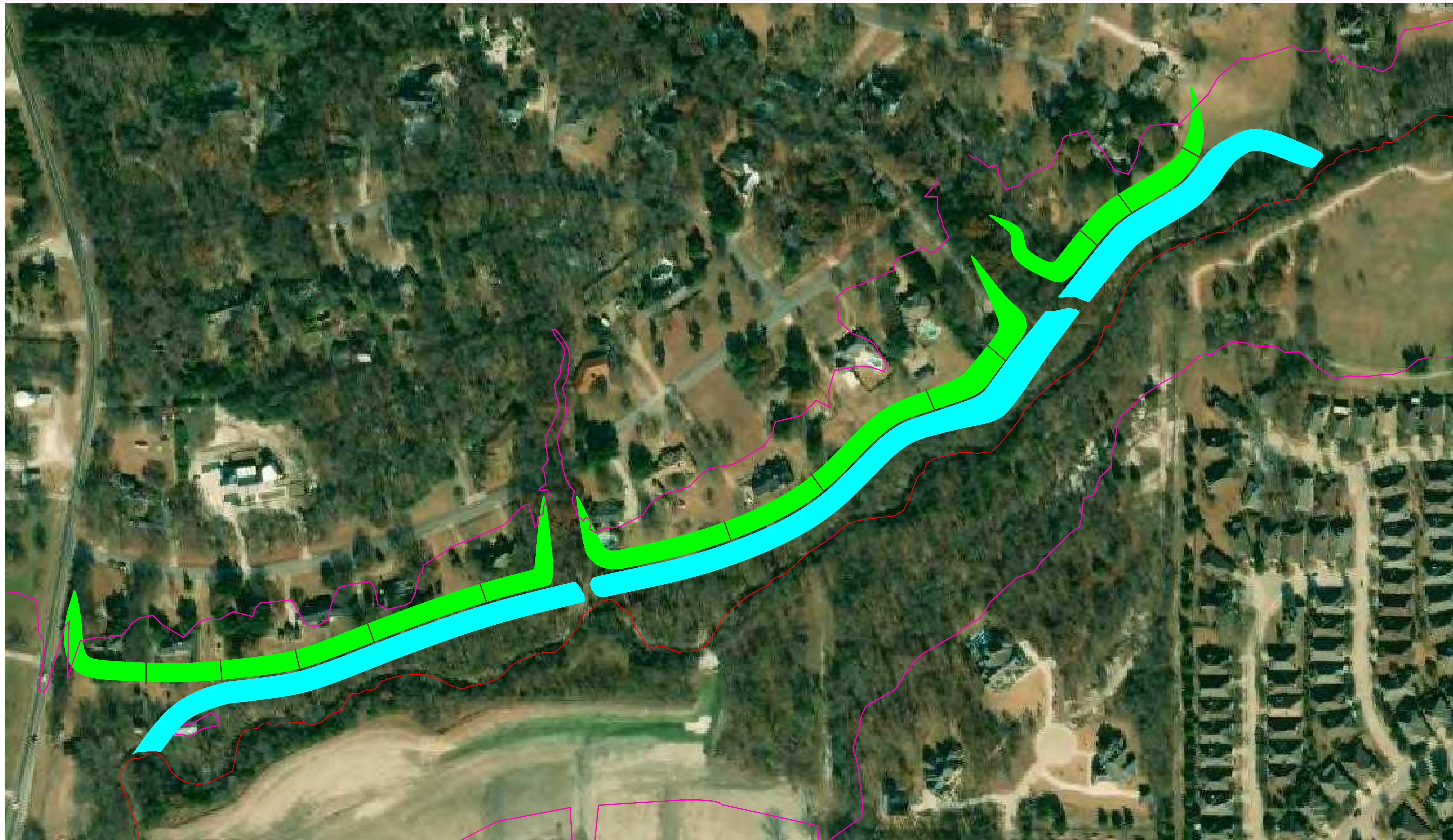

LEGEND

-  SLOAN CREEK FLOWLINE
-  FEMA 100-YR FLOODPLAIN
-  6-FT DEEP OVERFLOW CHANNEL
-  6-FT HIGH LEVEE
-  18-IN DRAIN & FLAP GATE

**EAST FAIRVIEW
MITIGATION ALTERNATIVES**

HIGH LEVEE AND O/F CHANNEL

TOWN OF FAIRVIEW
COLLIN COUNTY, TEXAS

HUITT-ZOLIARS
Huitt-Zoliars, Inc. Engineering & Surveying
 1717 McKinney Avenue, Suite 1400
 Dallas, Texas 75202-1236
 Firm no. F-761

SCALE AS NOTED	SHEET No.
DATE JUN 2020	

CAD FILE PATH:

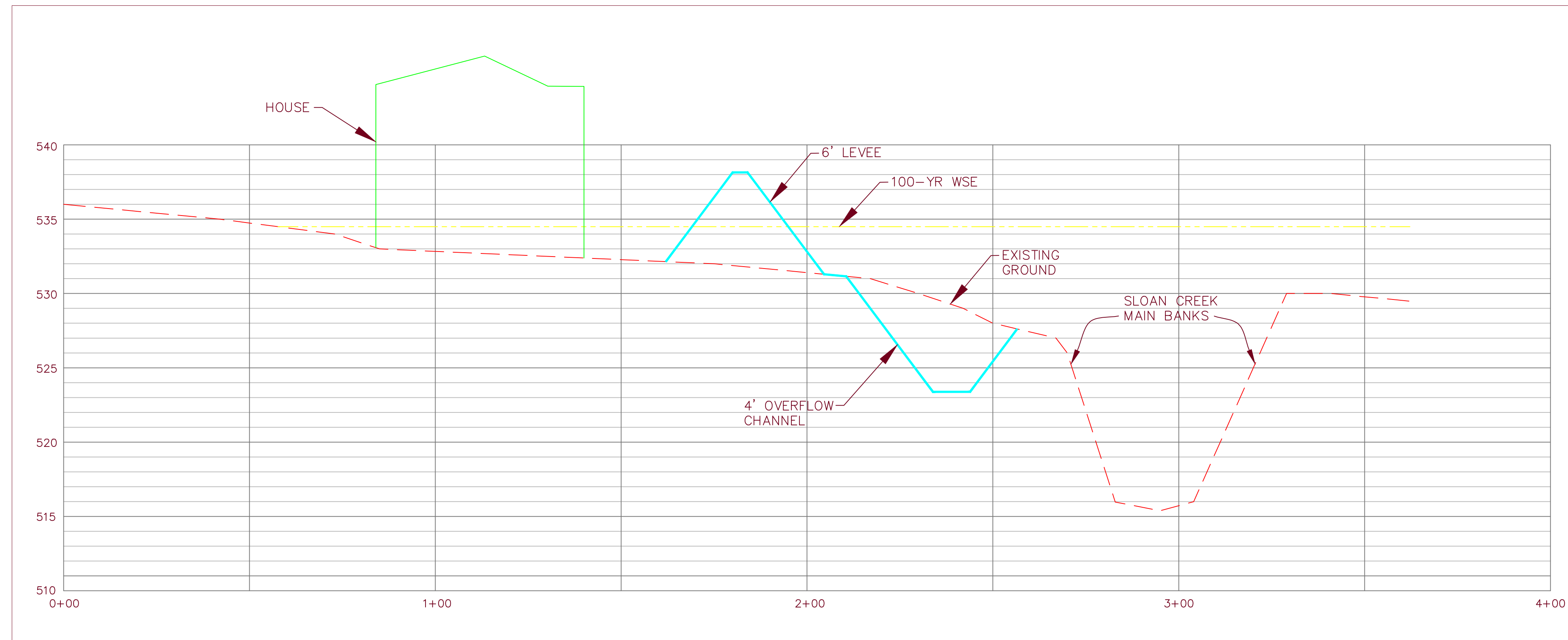

TYPICAL SECTION
SCALE: 1"=20' HOR; 1"=5' VER

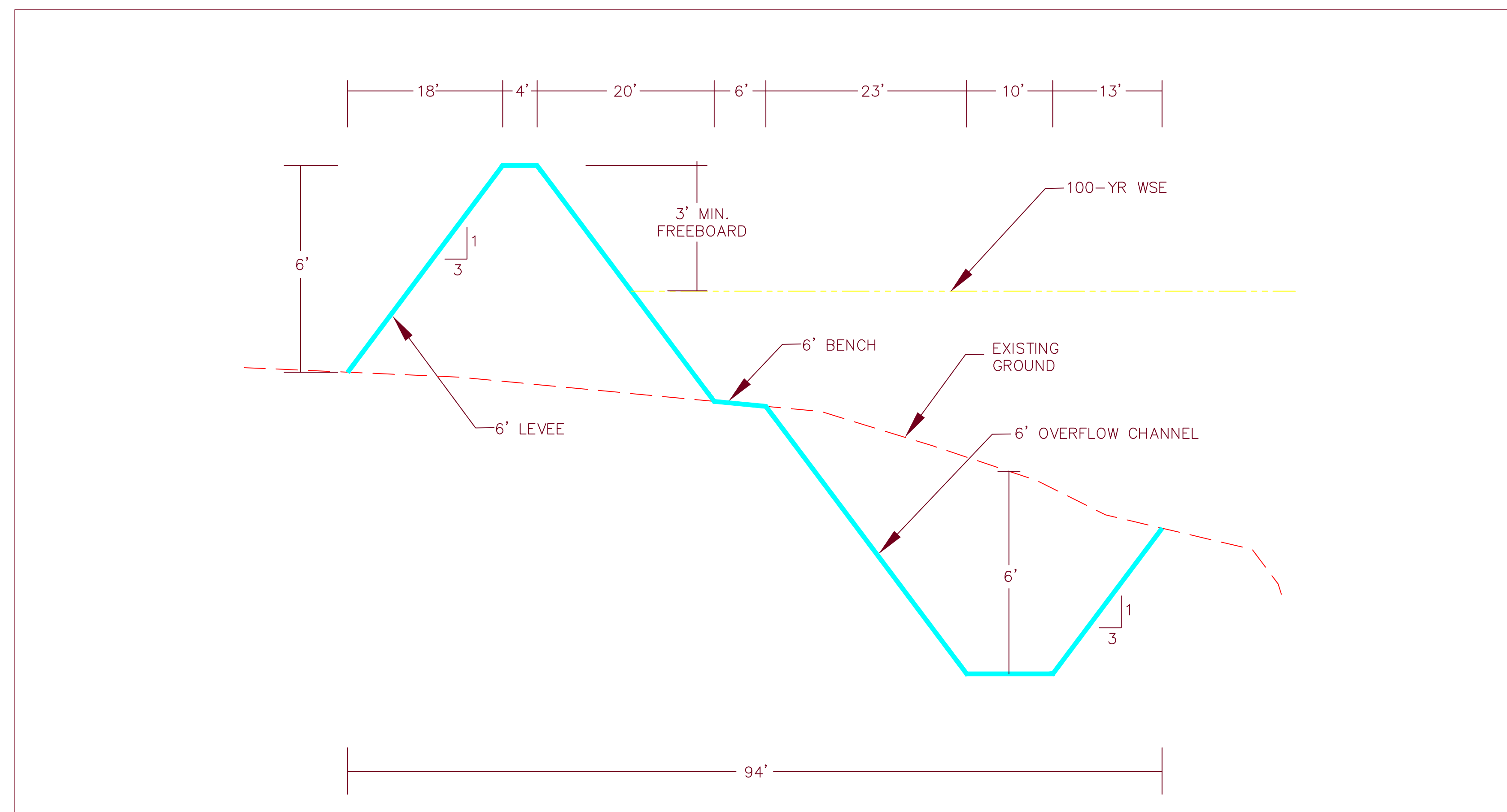

LEVEE AND OVERFLOW CHANNEL DETAIL
SCALE: 1"=10' HOR; 1"=2.5' VER

EAST FAIRVIEW MITIGATION ALTERNATIVES		
6' LEVEE & O/F CHANNEL DETAILS		
TOWN OF FAIRVIEW COLLIN COUNTY, TEXAS		
HUTT-ZOLIARS <small>Hutt-Zoliars, Inc. 1717 McKinney Avenue, Suite 1400 Dallas, Texas 75202-1236 Firm no. F-761</small>	SCALE AS NOTED DATE JUN 2020	SHEET No.

CAD FILE PATH:

East Fairview Drainage Study

The 18-inch diameter pipes will effectively drain the localized flows from each property. There are two locations where a stream carrying discharges from a large upstream area outfall into Sloan Creek. At these locations, the levees will be turned parallel to the streams to allow the larger discharges to drain along the natural streams, since it is impractical to have multiple large pipes or box culverts through the levees.

Large trees will need to be removed for the construction of the levees and overflow channels, in particular for the higher levee option, which has a larger footprint. The improvements are located within private properties, requiring temporary and permanent easements to be obtained for construction and future access for maintenance. A Preliminary Opinion of Probable Construction Cost was prepared for each levee alternative. The OPCC also shows expected costs for engineering, surveying, materials testing, bidding and construction services, easement documents preparation, and the FEMA LOMR for the 6-foot levee option. The OPCC for each levee alternative is found in the next two pages.

Preliminary Opinion of Probable Construction Cost
3' Levee and 4' Overflow Channel

6/11/2020

Item	Unit	Unit Price	Quantity	Cost
CONSTRUCTION				
MOBILIZATION	LS	\$ 25,000.00	1	\$ 25,000.00
SITE CLEARING	AC	\$ 2,000.00	8	\$ 16,000.00
TREE REMOVAL (12" DIA. PLUS)	EA	\$ 1,500.00	36	\$ 54,000.00
DEMOLITION	LS	\$ 25,000.00	1	\$ 25,000.00
CONSTRUCTION ENTRANCE	EA	\$ 2,100.00	2	\$ 4,200.00
SILT FENCE	LF	\$ 1.50	7000	\$ 10,500.00
ROCK CHECK DAM	EA	\$ 1,300.00	4	\$ 5,200.00
TREE PROTECTION FENCE	LF	\$ 5.00	4500	\$ 22,500.00
CHANNEL EXCAVATION	CY	\$ 10.00	9800	\$ 98,000.00
HAUL OFF SOIL MATERIAL	CY	\$ 20.00	5000	\$ 100,000.00
18" CMP DRAIN	LF	\$ 50.00	370	\$ 18,500.00
FLAP GATE FOR 18" CMP	EA	\$ 400.00	12	\$ 4,800.00
HYDROSEEDING	SY	\$ 2.50	34000	\$ 85,000.00
18" RIPRAP (24" LAYER)	CY	\$ 144.00	300	\$ 43,200.00
TOTAL CONSTRUCTION COST				\$ 511,900.00
ENGINEERING AND PERMITTING				
ENGINEERING (CIVIL, H&H, GEOTECH)				\$ 77,000.00
SURVEY				\$ 10,000.00
BIDDING				\$ 6,000.00
CONSTRUCTION ADMINISTRATION				\$ 6,000.00
MATERIALS TESTING				\$ 4,000.00
FEMA LOMR				\$ 25,000.00
EASEMENT DOCUMENTS				\$ 27,000.00
TOTAL ENGINEERING AND PERMITTING COST				\$ 155,000.00

Sub-Total	\$666,900
20% Construction Cost Contingency	<u>\$102,380</u>
Total	<u>\$769,280</u>

Preliminary Opinion of Probable Construction Cost
6' Levee and 6' Overflow Channel

6/11/2020

Item	Unit	Unit Price	Quantity	Cost
CONSTRUCTION				
MOBILIZATION	LS	\$ 25,000.00	1	\$ 25,000.00
SITE CLEARING	AC	\$ 2,000.00	11	\$ 22,000.00
TREE REMOVAL (12" DIA. PLUS)	EA	\$ 1,500.00	72	\$ 108,000.00
DEMOLITION	LS	\$ 25,000.00	1	\$ 25,000.00
CONSTRUCTION ENTRANCE	EA	\$ 2,100.00	2	\$ 4,200.00
SILT FENCE	LF	\$ 1.50	7000	\$ 10,500.00
ROCK CHECK DAM	EA	\$ 1,300.00	4	\$ 5,200.00
TREE PROTECTION FENCE	LF	\$ 5.00	4500	\$ 22,500.00
CHANNEL EXCAVATION	CY	\$ 10.00	18667	\$ 186,670.00
HAUL OFF SOIL MATERIAL	CY	\$ 20.00	1067	\$ 21,340.00
18" CMP DRAIN	LF	\$ 50.00	590	\$ 29,500.00
FLAP GATE FOR 18" CMP	EA	\$ 400.00	12	\$ 4,800.00
HYDROSEEDING	SY	\$ 2.50	47600	\$ 119,000.00
18" RIPRAP (24" LAYER)	CY	\$ 144.00	355	\$ 51,120.00
TOTAL CONSTRUCTION COST				\$ 634,830.00
ENGINEERING AND PERMITTING				
ENGINEERING (CIVIL, H&H, GEOTECH)				\$ 77,000.00
SURVEY				\$ 10,000.00
BIDDING				\$ 6,000.00
CONSTRUCTION ADMINISTRATION				\$ 6,000.00
MATERIALS TESTING				\$ 4,000.00
FEMA LOMR				\$ 25,000.00
EASEMENT DOCUMENTS				\$ 27,000.00
TOTAL ENGINEERING AND PERMITTING COST				\$ 155,000.00

Sub-Total	\$789,830
20% Construction Cost Contingency	<u>\$126,966</u>
Total	<u>\$916,796</u>

Streambank Erosion Control

Streambank erosion along Sloan Creek has caused the loss of trees and land at multiple locations in the Foxglen neighborhood and along the homes on Camino Real backing to the creek. The streambank erosion observed in Fairview is a common process observed in other urban streams in the DFW area and across the nation. Streambank erosion is a natural process in which the stream is constantly trying to reach a point of equilibrium. This equilibrium takes place as the flowing water re-shapes the stream to balance its forces with the resistance forces of the bank material in its new geometry. Erosion occurs when the forces exerted by flowing water exceed the resistance force of bank materials and vegetation. Erosion occurs in many natural streams with vegetated banks, both in urban and rural settings. The main causes of streambank erosion fall into four into four categories: geologic, climatic, vegetative, and hydraulic. These causes may act on their own, but most commonly they act concurrently. For instance, the increase in monthly and annual rainfall amounts in recent years in the Fairview is a climatic factor that contributes to streambank erosion on its own. The change in land use within the watershed due to new developments over the years, causing additional runoff is another factor on its own, but which also acts concurrently with the climatic change. Loss of vegetation in the banks whether due to natural causes or man-caused can also act on its own or in conjunction with the previous factors to contribute to streambank erosion. Channel geomorphology also influences the stream susceptibility to erosion. Does the channel have sharp bends or is its longitudinal alignment mostly uniform? Are the bank slopes steep or flat? What is the bank material, rock, clay, sandy? What is the streambed material? These are some of the main geologic factors that affect the rate of erosion in a stream. It is important to understand the causes of streambank erosion in order to develop an adequate site-specific solution that will address the issue and prevent it from returning.

Streambank protection can be achieved using vegetative plantings, soil bioengineering systems, and structural measures. Often, a combination of these categories is used to achieve a cost-effective and pleasing to the eye solution. Vegetative plantings are mostly used on small streams with lower channel velocities and shear stresses. They can also be used in combination with structural measures such as riprap, gabions, shotcrete, and reinforced concrete. Bioengineering solutions use vegetation and engineered products such as geogrids to provide slope stability and turf reinforcement mats in conjunction with vegetation to provide surface erosion protection. Structural measures consist of hard armoring, generally applicable to incised streams with high channel velocities.

This study included observation of reported erosion sites in Foxglen and a field evaluation of Sloan Creek between Harper Landing and the homes on Camino Real. Huitt-Zollars staff walked along the stream to determine the areas undergoing severe erosion, and to document vegetative cover, bank material, sinuosity, bank slopes, bank height, signs of streambed head cutting, aggradation and degradation around bends, and stream profile. Some parts of the stream could not be evaluated due to access difficulties related to the water level in the stream or heavy vegetation in the banks and overbanks. A total of 7 locations were identified as having undergone severe erosion, three in Foxglen and three east of the Country Club Road bridge. These locations are depicted in the map in the next page. An in depth analysis was performed to understand the erosion at each site and to provide recommendations for potential solutions.

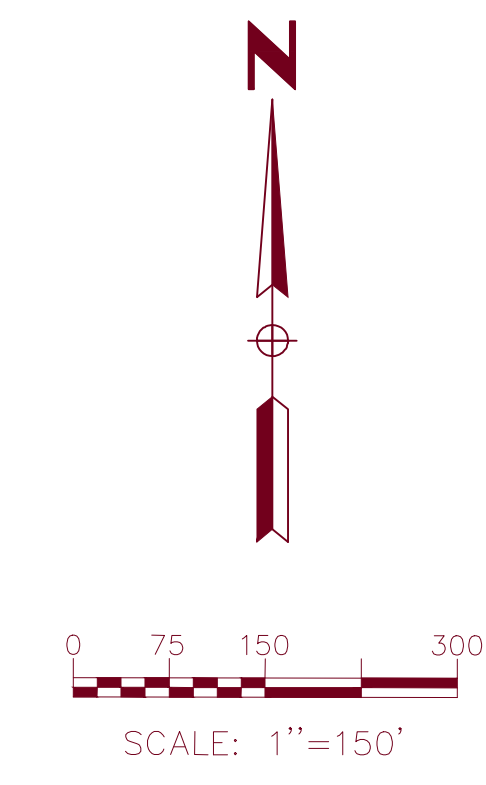

LEGEND

- SLOAN CREEK FLOWLINE
- ⑦ EROSION SITE IDENTIFICATION

EAST FAIRVIEW MITIGATION ALTERNATIVES		
EROSION CONTROL SITES		
TOWN OF FAIRVIEW COLLIN COUNTY, TEXAS		
HUITT-ZOLIARS <small>Huitt-Zollars, Inc. Engineering / Surveying 1717 McKinney Avenue, Suite 1400 Dallas, Texas 75202-1236 Firm no. F-761</small>	SCALE AS NOTED	SHEET No.
	DATE JUN 2020	

CAD FILE PATH:

East Fairview Drainage Study

What follows is the analysis performed for each site, based on field observations and review of the effective hydraulic model for Sloan Creek. At the end of the analysis for each site, recommendations for potential solutions are provided for each site.

Site 1

This area is located in the back of the property at 580 Maple Lane, where an unnamed tributary joins Sloan Creek. Erosion was observed in the unnamed tributary as well as the main stream. Bank height is approximately 15 feet. Bank slope is very steep, nearly vertical. Bank material is mostly clay. Natural vegetative cover consisting of brush, grass, bushes, and trees have been partially washed away exposing the bank in some areas, and uprooting large trees. Approximately 20 feet of overbank has been lost due to erosion. The main dwelling in the property is at a safe distance (at least 80 feet) from the eroded bank, but two secondary structures and a light pole guy wire are very close to it. The stream alignment in this area has sharp 90-degree bends causing the flowing water to hit the streambank perpendicularly. As vegetation is lost to erosion the site will become increasingly more susceptible to erosion. The effective hydraulic model for this area indicates the 100-year channel velocities are between 9 and 10 feet-per-second. These are high velocities with a high erosion potential, particularly with the loss of protective vegetation in the streambanks.



Severe bank erosion causing tree uprooting and loss of overbank

East Fairview Drainage Study

Site 2

This site is in the back of the property located at 1041 Pecan Drive in the Foxglen neighborhood. Bank is approximately 16 feet in height, partially covered with grass, brush, and trees. Bank slope is approximately 1:1. Large portions of overbank has been lost due to erosion. Large trees have been uprooted and are in imminent danger of being washed away. This section of the channel is very sinuous, with curves and turns, which tend to make the banks more susceptible to erosion. The 100-year channel velocity in this area is between 7.6 and 10 feet per second, which are considered erosive velocities for a natural stream. The main dwelling is approximately 70 feet away from the bank. An existing gazebo sits near the top of bank, facing the potential for being washed away as erosion progresses.



Uprooted tree and gazebo in the background

Site 3

Erosion has occurred in the back of the property located at 561 Cottonwood Place, causing loss of land. Banks are approximately 15 feet in height with a steep slope, partially covered by trees, brush, grass and bushes. The stream alignment makes a tight curve along the property's northwest corner, where erosion is more severe. The main dwelling sits approximately 40 feet from the top of bank, while the driveway is approximately 30 feet from the top of bank. Channel velocities in this section of the stream varies between 4 and 7 feet per second, which are moderate to high.

East Fairview Drainage Study

Site 4

This site is located 200 feet east of the Country Club Road bridge. The erosion has taken place around a sharp bend in the stream, which appears to be the area graded to allow the flow from the main creek to enter the overflow channel constructed with the Harper Landing development. Bank material is a sandy clay type, which is not resistant to high forces from flowing water. Currently there are no structures in the property. The HEC-RAS model shows a 100-year channel velocity of 18 feet per second in this area. The main reason for this extremely high velocity is the location just downstream of the bridge, where contraction and expansion coefficients are higher and the flows are constricted through the bridge causing downstream velocities to increase. Erosion is expected to continue along the stream bend.



Erosion along sharp bend on the stream

East Fairview Drainage Study

Site 5

This site is located just north of site 4, along another sharp bend in the stream. The bank is approximately 14 feet in height and nearly vertical due to erosion. No vegetation is left in the eroded bank with the exception of overhanging tree roots. Aggradation was observed in the opposite side of the stream, caused by sediment deposition due to lower velocities along the inner bend. A shed is located a few feet from the top of eroded bank. Another secondary wood structure is located a few feet further. The main dwelling is located over 150 feet away from the stream. The 100-year channel velocities in this area transition from 18 to 5 feet per second, around the stream bend. The sharp bend helps to slow the velocity down at the cost of eroding the bank. Erosion is expected to continue along the stream bend, taking additional overbank area, trees, and possibly one of the secondary structures closer to the creek bank.



Bank erosion in the outer bend, and aggradation in the inner bend.

East Fairview Drainage Study

Site 6

This site is located about 200 feet east of site 5. Bank height, material and vegetative cover is similar to site 5, but the banks are not as steep. Aggradation was observed along the inner bend, and degradation along the outer bend. No structures were visible near the stream. The main dwelling is more than 100 feet away from the stream. The average channel velocity is 3 feet per second as shown in the hydraulic model. This is considered a low velocity, not expected to cause streambank erosion. Headcutting was observed in this area suggesting the stream profile has dropped.



Bank erosion in the outer bend, and aggradation in the inner bend.

East Fairview Drainage Study

Site 7

This area is located about 300 feet east of site 6. Severe erosion was observed around the inner stream bend, with no vegetative cover left and trees being uprooted. The bank material appears to be the erodible sandy clay. The bank is nearly vertical and about 14 feet in height. Channel velocity in this section of the stream is approximately 9 feet per second, which is considered high and erosive for a natural stream. The main dwelling in the property is about 100 feet away from the eroded streambank.



Severe erosion at stream outer bank

The field evaluation limits extended further east from site 7, where small to moderate erosion was observed along sections of the stream.

Potential Options

The approach to handle streambank erosion will determine the solution. Several factors must be considered and prioritized to narrow down the solutions available. The most important factors to consider include cost, constructability, aesthetics, site access, the need for easements, maintenance, and performance. The approach taken in this study is to find the most cost-effective solution that could be constructed given each site's unique condition, achieving the goal of protecting the streambank with minimum or no maintenance. Appearance and cost are usually directly proportional. Therefore, aesthetical appearance was placed low in the priority list in order to minimize cost.

Before discussing a solution to each site, it is important to understand the different options available. As mentioned previously, vegetative planting consists of the placement of shrubs, grass, and trees in specific areas in the bank, and are applicable to small streams with low channel velocities. Bioengineering methods combine engineered products with vegetation. Structural products provide a hard armoring solution to streams with higher velocities and erosion potential. Also, a combination of these techniques can be used in many cases to provide a balance between cost and appearance. Below is a series of typical sections and photographs of the most common options used to control and prevent streambank erosion.

Gabion Retaining Wall With Tiebacks

Gabions are essentially metal baskets filled with stone. The baskets are stepped back creating a slope or batter. The baskets are usually anchored with tiebacks made of steel, which are embedded into rock or into a stable material beyond the failure plane of the slope. Gabions provide a somewhat natural look with the stones and are generally cost competitive when compared to other options. A drawback of gabions in streams with high velocities and moving debris is that the wires can become damaged or brake when tree trunks and large debris collide with the wall. This could cause the wall to sag, move, and even fail if the issue is not immediately addressed. A typical gabion wall section and photograph can be seen in the following page.

East Fairview Drainage Study

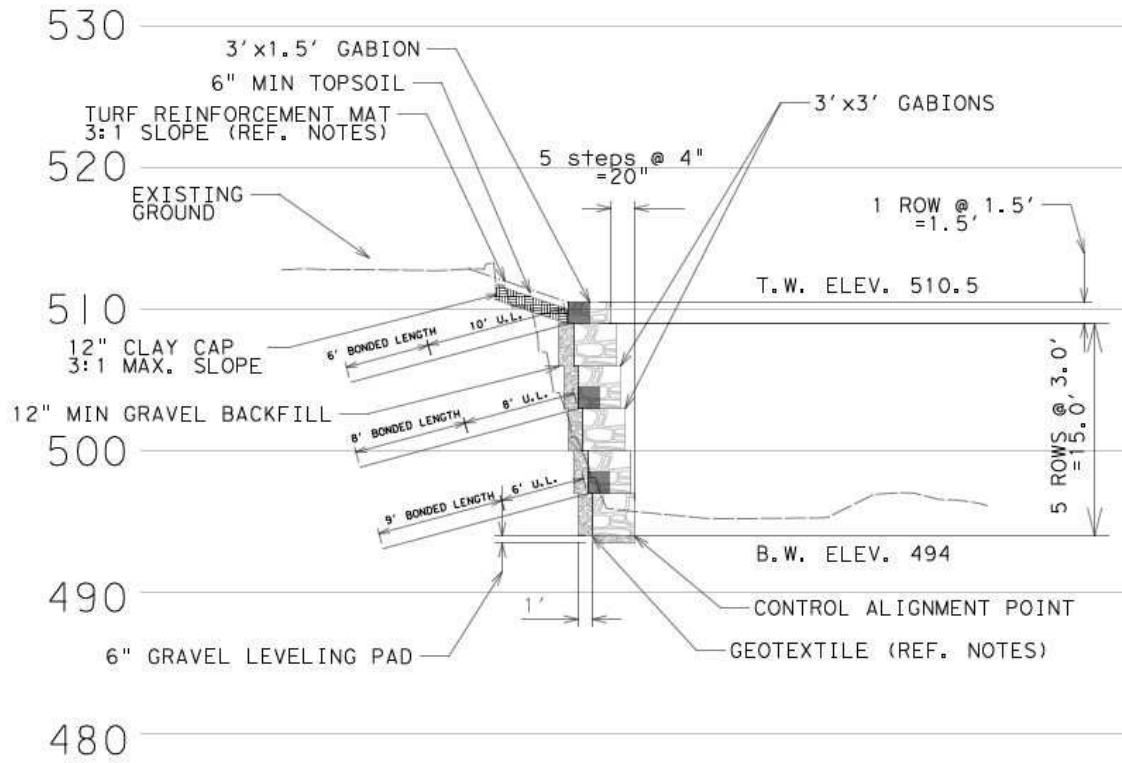

R-Rap Soil Reinforced Wall Retaining Wall

R-rap walls consist of concrete bags with reinforcement bars. They can be anchored with tiebacks or, as in the typical section below, have geogrids to reinforce the soil providing slope stability. A foundation made of reinforced concrete or gabion baskets are usually used to support the wall, prevent settlement and overturning, and protect the toe of the bank. This is one of the most cost-effective designs available, due to the relatively low cost of geogrids compared to steel anchors, and the lower cost of concrete bags compared to reinforced concrete or gabions. These types of walls are not as sturdy as other retaining walls, but they can perform satisfactorily when properly designed and constructed.

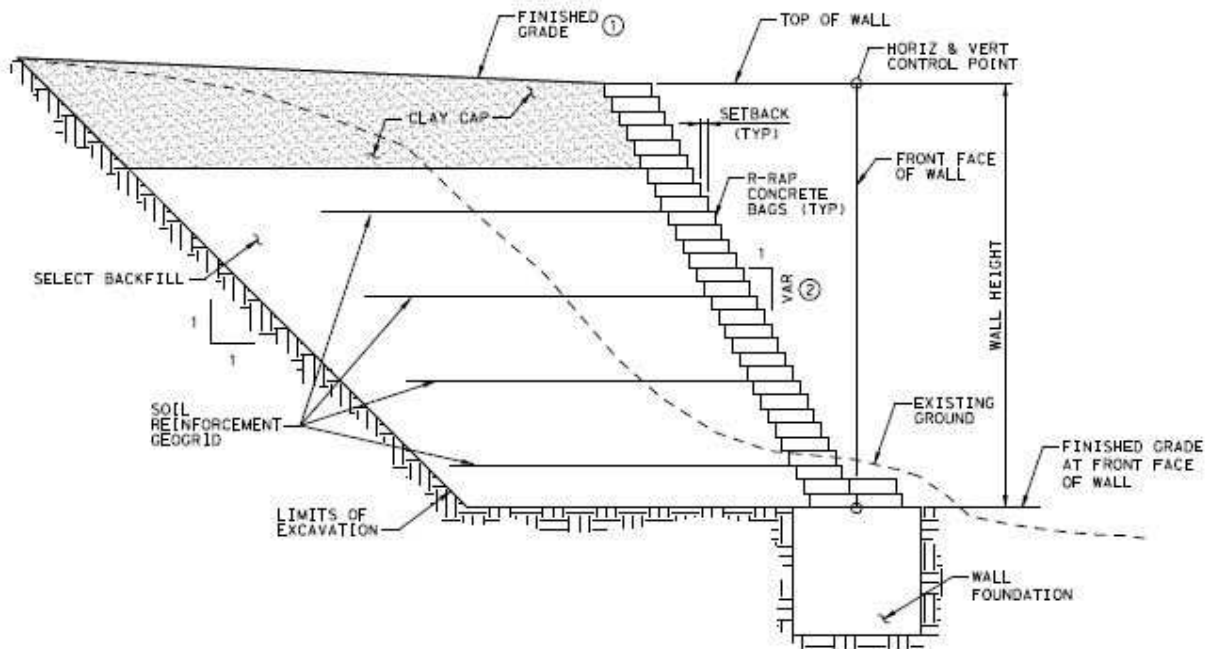

R-RAP AND GEOGRID



Reinforced Concrete Retaining Wall

These are some of the stronger and more durable walls, as well as more costly than r-rap or gabions. The face is constructed with cast-in-place reinforced concrete. A shotcrete layer is applied to the bank and soil or rock nail anchors are installed to prevent overturning.

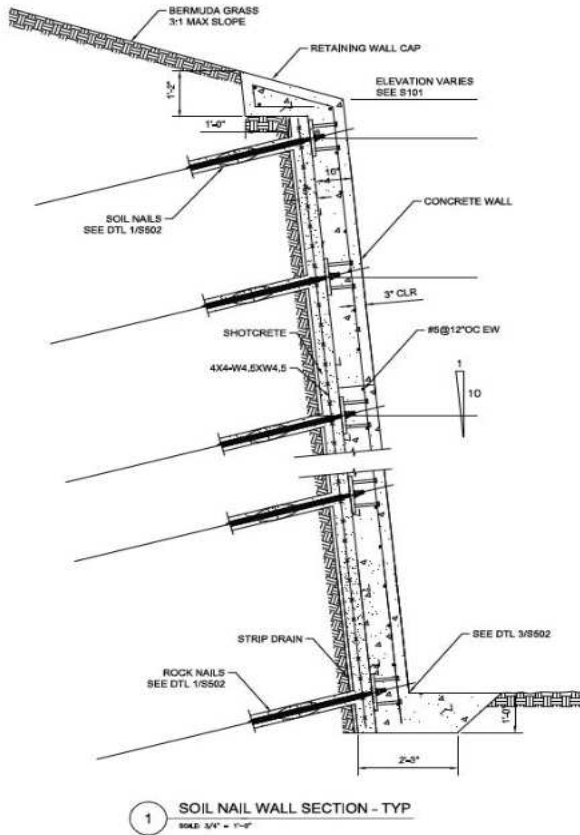

Concrete Block Retaining Wall

These walls utilize snap-in-place pre-cast concrete blocks. Their appearance is attractive and the speed of construction offsets for some of the high material cost. They are strong and durable. Usually they are anchored with tiebacks or backfilled with granular material and geogrids to provide slope stability.



Masonry Gravity Retaining Wall

These walls rely on their own weight to provide slope stability. Therefore, they are more “massive” than mechanically stabilized walls. The wall can be several feet thick and the foundation is large. These walls fall in the middle of the range for cost and are best fit for areas where tieback anchors or soil reinforcement is not an option.

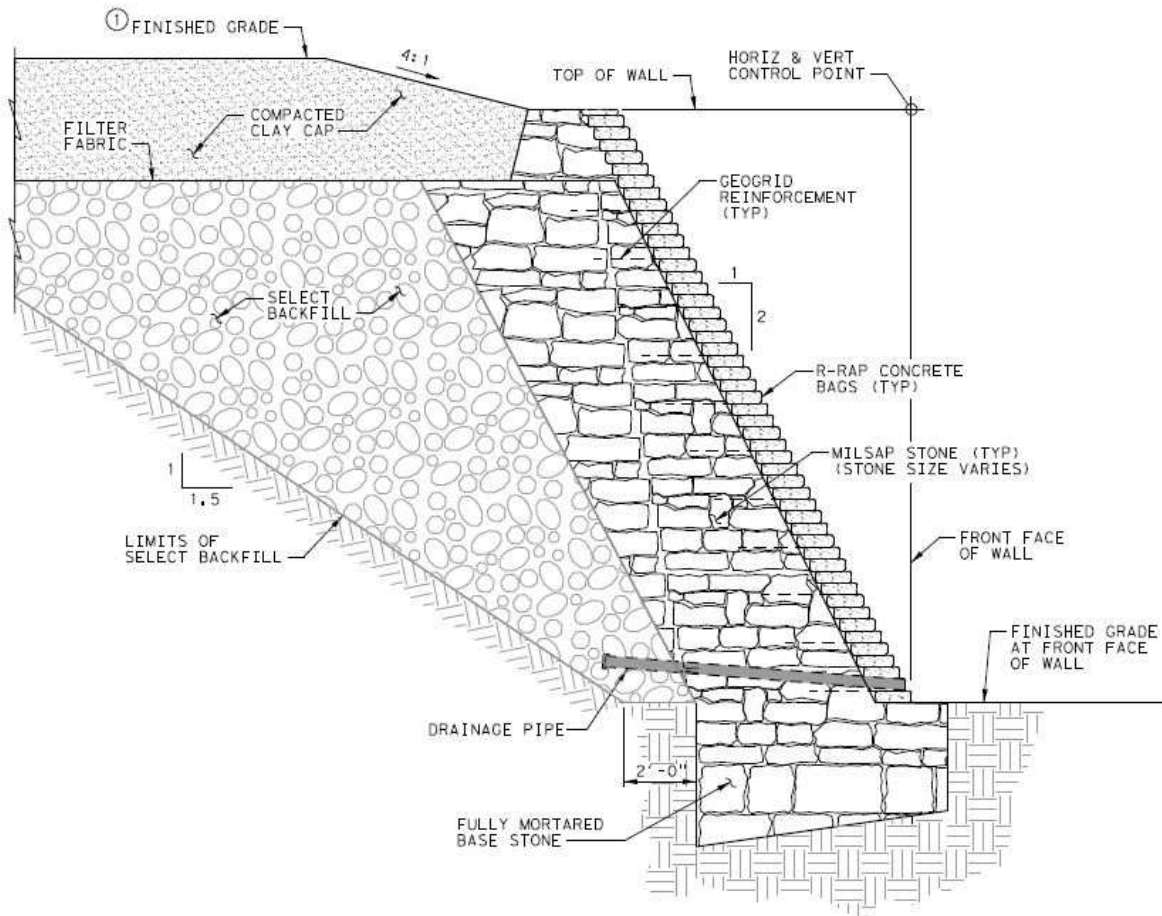

R-RAP AND MASONRY STONE

Hybrid Walls

Hybrid walls combine different methods of erosion control to save on cost and provide an improved appearance. The typical section below shows a hybrid wall with gabions in the bottom half. In the top half, turf reinforcement mat was used in conjunction with switch grass to provide surface erosion protection and geogrids used to reinforce the steep 1:1 slope, providing stability.

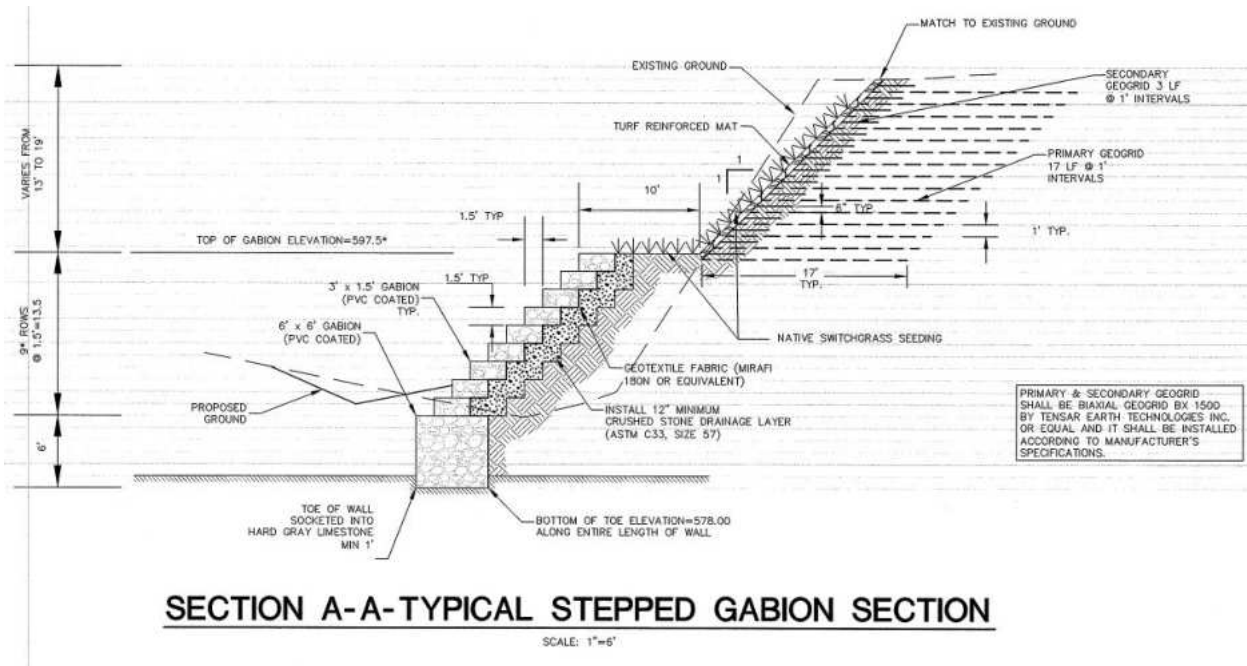

Soil And Rock Nail Retaining Walls

Soil or rock nail walls consist of pneumatically placed concrete, commonly referred to as shotcrete, applied to the streambank over a wire mesh that serves as reinforcement. Soil or rock nails made of steel anchor the shotcrete surface. A surface layer of reinforced concrete, r-rap, or other material is usually applied to the shotcrete surface. Soil and rock nail walls work well in situations where the surface land behind the wall cannot be disturbed or when the streambank cannot be disturbed due to the danger of collapsing the bank itself or adjacent structures.

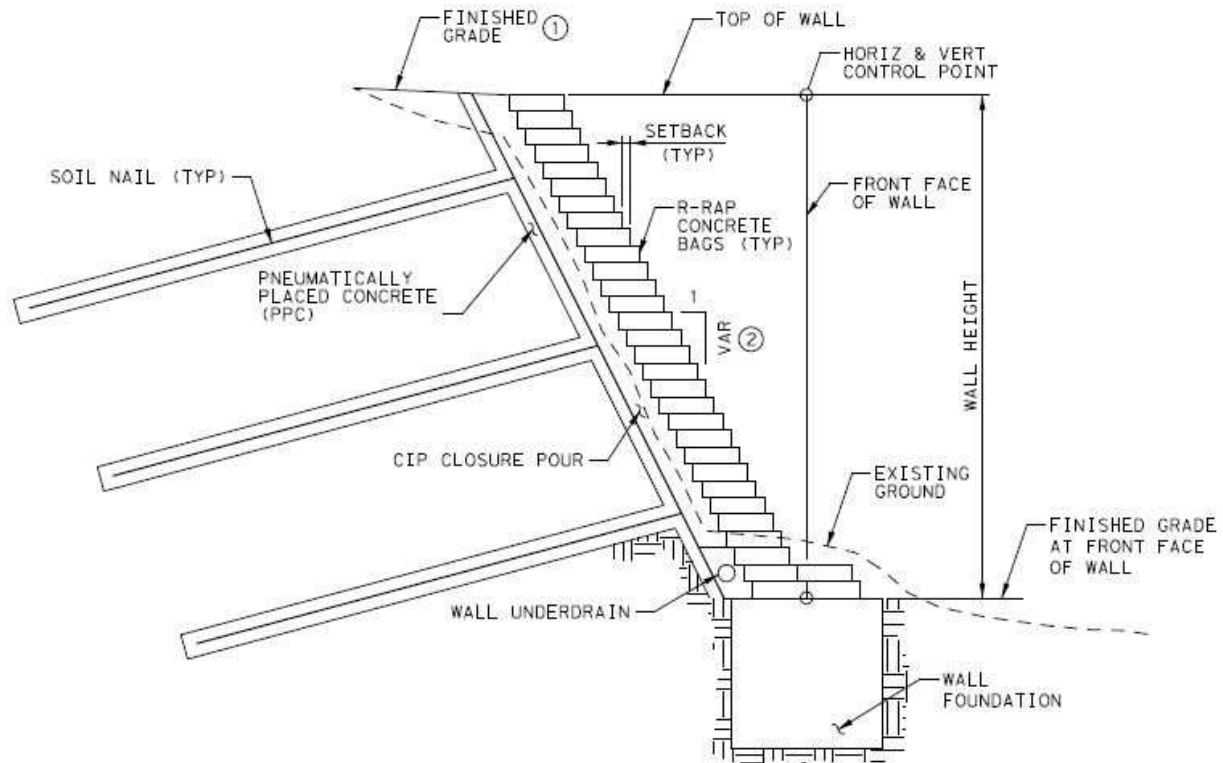

SOIL NAIL

Recommendations for Potential Solutions

It is important to note that these recommendations are made solely on field evaluations of the sites and review of the effective hydraulic model for Sloan Creek and are meant to provide a conceptual level potential solution to the streambank erosion issues. Additional information is required to determine the viability of each presented solution, including a geotechnical investigation with soil borings and materials testing at each site. The construction costs presented below are based on an average “per square foot” cost for recent streambank erosion control projects completed by Huitt-Zollars and are intended to provide an approximate construction cost range that can be expected for each site. Cost estimates assume access to the project sites down to the creek bed will be provided from within the individual properties for the lots along Camino Real and from off-site locations for all other lots. Environmental permits from the USACE requiring a pre-construction notification may be needed depending on the length of impacted streambank, and the presence of protected natural habitats, wetlands, or historical sites. It is assumed that access to the creek bed will be obtainable for construction equipment and the necessary easements will be in place. Estimated construction cost does not include engineering services for the design and preparation of construction plans. The focus of these recommendations is to provide a viable cost-effective engineering solution and its approximate cost range to guide City officials in making decisions.

Site 1 – This site is located in a section of the stream with high velocities, sharp bends, soft bank material, and has suffered loss of natural vegetative cover. Given the site conditions, geometry, stream alignment and geology, it is unlikely that placing vegetation back in the bank will protect it from future erosion. A hard armoring alternative is the most adequate solution for this site. A hybrid solution combining bioengineering and hard armoring is also an adequate option for this site. Gabions are not recommended along Sloan Creek due to the size and quantity of tree logs and other materials that move through the creek that could damage the baskets. The recommended design is a reinforced concrete wall or concrete block wall up to half of the bank height, transitioning to a geogrid-reinforced slope with turf reinforcement mat used in conjunction with a native grass for the top part. Removal of trees and of one secondary structure, and relocation of the power pole guy wire would be necessary. This wall would be essentially maintenance free after construction. The length of the wall is approximately 220 feet and the construction cost would be approximately \$400,000.

Site 2 – The conditions at site 2 allow for the construction of an r-rap wall, possibly with geogrid soil-reinforcement, and a gabion foundation. This design would require removal of the gazebo and trees in the bank where the wall will be constructed. The retaining wall would be approximately 180 feet long and 16 feet in height. Construction cost would be between \$300,000 and \$350,000.

Site 3 – The main dwelling and the driveway in this site are closer to the streambank than at the other sites. This space constraint will make a soil nail wall a more viable design, since the bank will not have to be disturbed nor the land behind the wall. The soil nails will extend a certain length, possibly between 10 feet to 25 feet, perpendicular to the bank. Requiring a permanent retaining wall easement. The wall length would be about 180 feet, with an average height of 15 feet, and would extend west into the adjacent property. The construction cost is expected to be in the range of \$400,000 to \$450,000.

East Fairview Drainage Study

Site 4 – Left unchecked, this area is expected to continue to erode in the direction of the Harper Landing overflow channel, as a result of the very high channel velocities. A simple solution in this area is to install grouted riprap along the bend and another 30 feet passed the bend as the stream turns north. A toe wall extending approximately 3 feet underground can stabilize the toe of the slope and prevent undermining. At both ends, the riprap should be turned into the embankment for a few feet to prevent it from being outflanked at the ends. The length of grouted riprap protection is about 220 feet and the average height is 12 feet. The construction cost is expected to be between \$350,000 and \$400,000.

Site 5 – An r-rap retaining wall anchored with tiebacks would be an adequate solution for this site. A less land disturbing alternative is a shotcrete with soil nail retaining wall. The length around the bend plus an additional 30 feet passed the bend should be protected. The length of streambank protection needed is about 150 feet and the average height is 14 feet. The construction cost is expected to be between \$300,000 and \$350,000.

Site 6 – Although channel velocities are low, erosion around the bend is noticeable. Very little vegetation is left to protect the bank from more erosion. This site would be a good fit for a hybrid wall consisting of hard armoring for the bottom 5 feet and vegetative planting for the remaining bank height. The hard armoring portion could be constructed with concrete blocks, which for this shorter height would act as a gravity wall without the need for anchors or soil reinforcement behind the wall. The bank slope can be re-built between the concrete block wall and the existing bank, filling the area with new soil. A combination of native grass, shrubs and small trees can be planted on the re-built slope to provide erosion protection. The length to be protected is about 200 feet, of which 5 feet would be a concrete block retaining wall and 10 feet would be vegetative planting surface. The construction cost is expected to be between \$150,000 and \$200,000.

Site 7 – This site is similar to site 5 and it would require a similar solution such as an r-rap retaining wall either anchored with tiebacks or with soil reinforcement behind the wall to provide slope stability. The length of the wall is about 150 feet and the height is 14 feet. The expected construction cost is between \$300,000 and \$350,000.

Floodplain Mapping

The effective FEMA floodplain boundaries are based on the 2018 LOMR for Sloan Creek and some of its tributaries. The hydraulic model for the study supporting the LOMR used the terrain data available at the time. Since then, the Town has obtained new Lidar terrain data. Huitt-Zollars updated the cross-sections in the effective hydraulic model with the new terrain data to determine if there were any changes in the 100-year floodplain boundaries. The analysis focused in the area from just upstream (west) of the Country Club road bridge to Heritage Ranch. This section of the stream is where some of the homes are within or very near the 100-year floodplain. The floodplain map showing the effective and the updated 100-year floodplain boundaries is found in the next page. The updated floodplain is narrower in some places and wider in other places when compared to the effective floodplain, but the differences are generally small. The updated boundary reflecting the new topography places the main dwelling at 1210 Camino Real in the floodplain, and removes the main dwellings in the properties located at 1220 Camino Real and 1180 Camino Real from the floodplain. The two homes that appear to be out of the floodplain based on the new topographic data could be officially removed from the floodplain with an Elevation Certificate upon verification by survey that the lowest adjacent grade at the structure is higher than the effective 100-year water surface elevation. A survey of the structure at 1210 Camino Real can be performed to determine whether or not the house is in the floodplain.

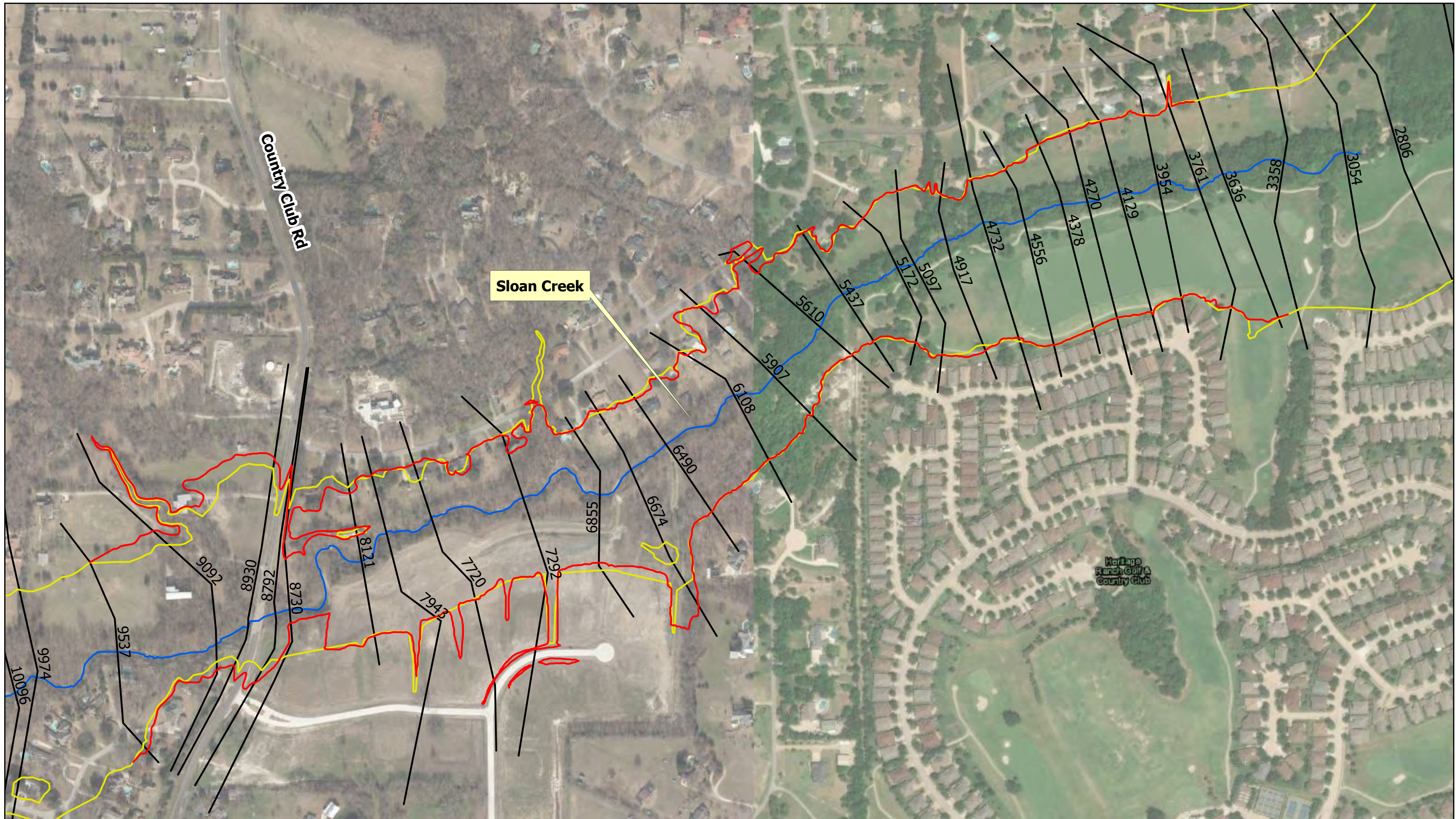

Legend

- Stream Centerline
- Effective 100 Year Floodplain
- Cross Section
- Revised 100 Year Floodplain (based on 2018 LiDAR data)

Floodplain Map

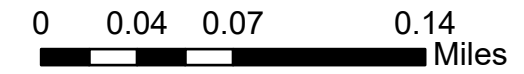

HUITT-ZOLLARS Firm No. F-761
 HUITT-ZOLLARS, INC. ENGINEERING / SURVEYING
 1717 MCKINNEY AVENUE - SUITE 1400
 DALLAS, TX 75202



Conclusion

Several alternatives were analyzed to develop mitigation measures aimed at reducing the frequency of flooding along the Sloan Creek floodplain in the eastern part of Fairview. The mitigation measures analyzed were:

- Measure the impact of requiring on-site detention for the remaining 320 acres of undeveloped/underdeveloped available land for development in the Sloan Creek watershed.
- Analyze the benefits of providing a regional detention facility.
- Determine the required length, height, and width of a levee and overflow channel to remove from the floodplain the homes along Camino Real backing to Sloan Creek.

The final task was to do an in-depth analysis of erosion sites along a specific section of Sloan Creek and determine potential solutions to control streambank erosion. Below is the conclusion that can be drawn from the results of this study.

On-Site Detention

Results from the hydrologic models indicate the impact to Sloan Creek associated with onsite detention for any arrangement in the number and location of detention sites is insignificant. The on-site detention facilities can, however, provide a significant localized reduction in peak discharges to the properties within the downstream zone of influence of each site as needed.

Regional Detention

An off-channel detention facility located approximately 1000 feet west of Parkdale Drive will provide a reduction in 100-year peak discharges to the eastern part of Fairview. The reduction will translate in a decrease in the 100-year water surface elevation along Sloan Creek of up to 0.3 ft. The decreases in water surface elevation are not very large, and will contribute to a small degree to alleviate flooding along Sloan Creek from approximately 1000 feet west of Parkdale Drive to Heritage Ranch. The off-channel regional detention facility based on the conceptual design and model will help to offset some of the increase in the frequency of flooding observed in recent years, but its impact will not be large enough to remove homes out of the floodplain.

Levee

The construction of a 3-foot high levee and overflow channel parallel to Sloan Creek in the north side of the stream can remove from the 100-year floodplain the homes along Camino Real shown to be within the effective FEMA floodplain. The levee should be built in conjunction with an overflow channel to offset increases in BFEs and to provide the material for the structure. In order to officially remove the homes from the FEMA floodplain the levee would need to be 6-foot high to meet FEMA freeboard requirements for levees. This option would also require a larger and deeper overflow channel.

Streambank Erosion Control

Moderate to severe erosion at multiple studied areas along Sloan Creek can be handled with structural measures, bioengineering methods, vegetative plantings, and a combination of these methods. Each site will require a solution tailored to its unique conditions and constraints. Alternatives have been presented for each studied site along with an expected construction cost range.

APPENDIX A

EFFECTIVE DRAINAGE AREA MAP

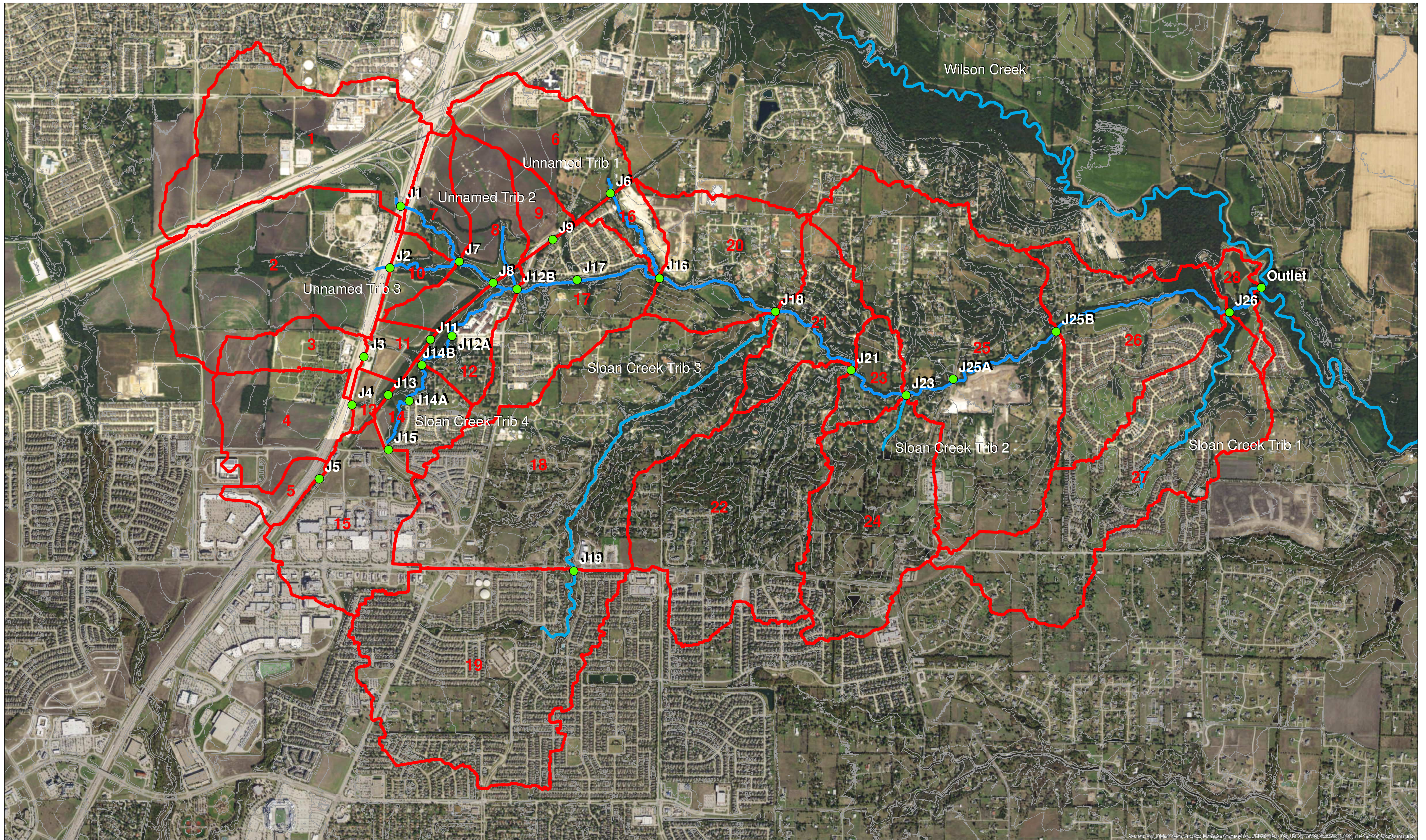

Legend

- Junctions
- Subbasin

Existing Drainage Area Map

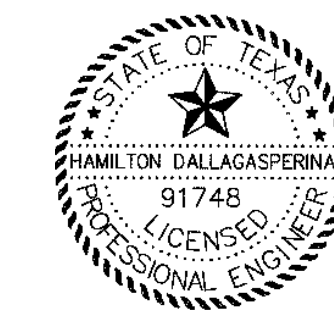

7/26/18



HUITT-ZOLIARS

Firm Registration No. F-761



Hamilton Dallagasperina

APPENDIX B

LAG TIME CALCULATIONS

2yr - 24hr rainfall depth (in)
3.6

DRAINAGE AREA 20A

PRE-DEVELOPMENT Flow Phase One	Type: Sheet Flow	
	Length:	100 ft
	"N" Value	0.15 from tables
	Top Ele.	632
	Bottom El	631
	Slope:	0.01 ft/ft
Computed 'T'		12.20 Minutes

PRE-DEVELOPMENT Flow Phase Two	Type: Shallow Concentrated Flow	
	Surface:	u
	Length:	1062 ft
	Top Ele.	631
	Bot. Ele.	616
u=unpaved p=paved	Slope:	0.01 ft/ft
	Velocity:	1.92 ft/sec
Computed 'T':		0.154 hr, or 9.24 Minutes

PRE-DEVELOPMENT Flow Phase Three	Type: Open Channel Flow	
	Length:	2370 ft
	Velocity:	5 ft/sec (assumed)
Computed 'T':		0.132 hr, or 7.9 Minutes

PRE-DEVELOPMENT Total Flow Summary	Time of Concentration	
	Total T_c =	29.4 Minutes
	Lag Time	
	T_{LAG} =	17.6 Minutes
	$T_{LAG}=0.6 \times T_c$	T_{LAG} = 0.29 Hours

DRAINAGE AREA 20B

PRE-DEVELOPMENT Flow Phase One	Type: Sheet Flow	
	Length:	100 ft
	"N" Value:	0.15 from tables
	Top Ele.	611
	Bottom El	610.5
	Slope:	0.005 ft/ft
Computed 'T'		16.10 Minutes

PRE-DEVELOPMENT Flow Phase Two	Type: Shallow Concentrated Flow	
	Surface:	u
	Length:	819 ft
	Top Ele.	610.5
	Bot. Ele.	607
u=unpaved p=paved	Slope:	0.00 ft/ft
	Velocity:	1.05 ft/sec
Computed 'T':		0.217 hr, or 13.02 Minutes

PRE-DEVELOPMENT Flow Phase Three	Type: Open Channel Flow	
	Length:	3419 ft
	Velocity:	5 ft/sec (assumed)
Computed 'T':		0.19 hr, or 11.4 Minutes

PRE-DEVELOPMENT Total Flow Summary	Time of Concentration	
	Total T_c =	40.5 Minutes
	Lag Time	
	T_{LAG} =	24.3 Minutes
	$T_{LAG}=0.6 \times T_c$	T_{LAG} = 0.41 Hours

APPENDIX C

EFFECTIVE TOPOGRAPHIC WORKMAP

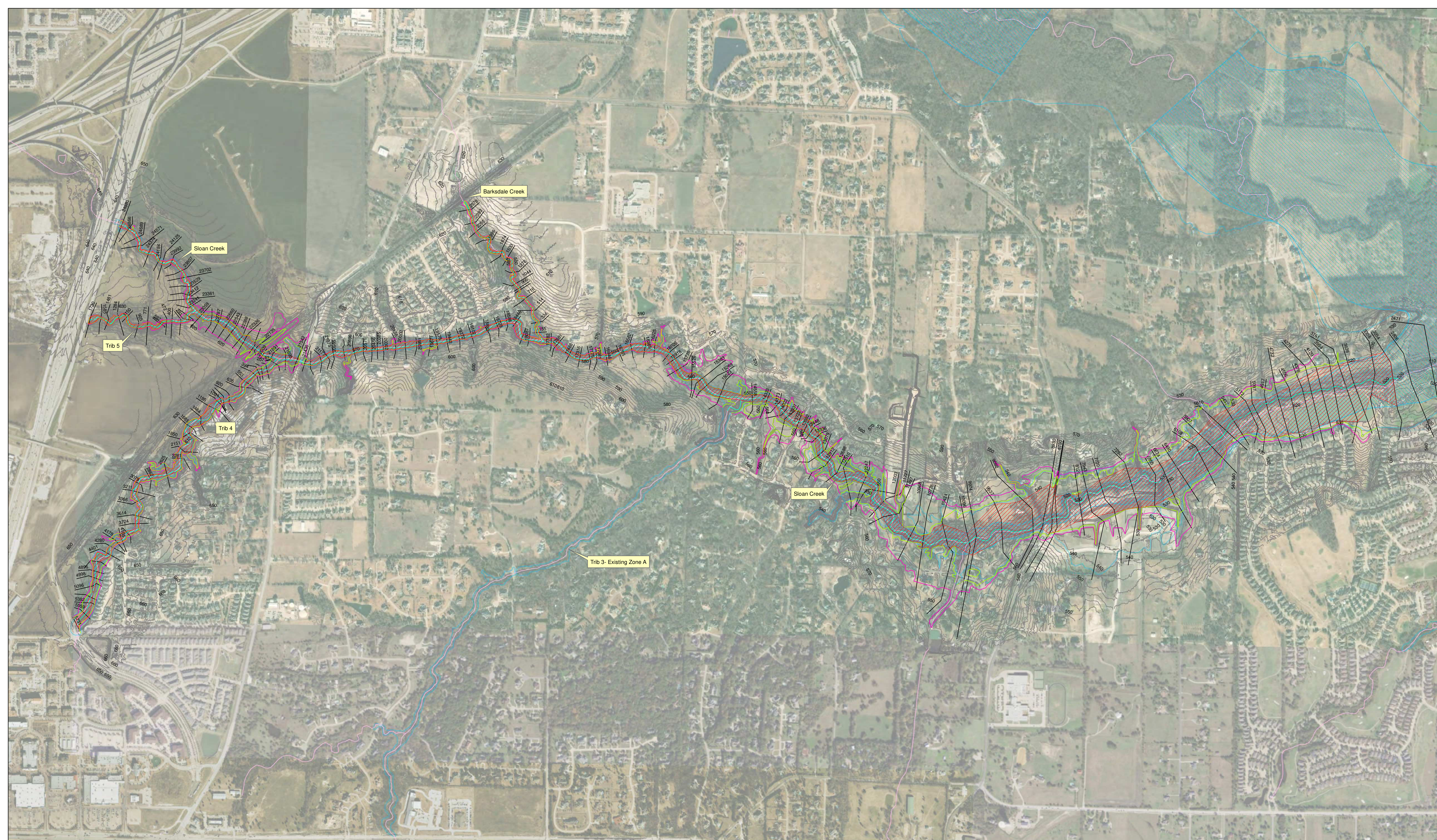

- Legend**
- CrossSections
 - ExistingRiver
 - ▨ 100YearFloodway
 - ▨ 100YearFloodplain
 - ▨ 500YearFloodplain
- FEMA Zone**
- ▨ Effective Floodway
 - ▨ Effective 500 Year Floodplain
 - ▨ Effective 100 Year Floodplain A
 - ▨ Effective 100 Year Floodplain AE
 - EffectiveFlowline

Topographic Map

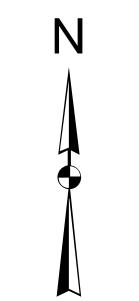
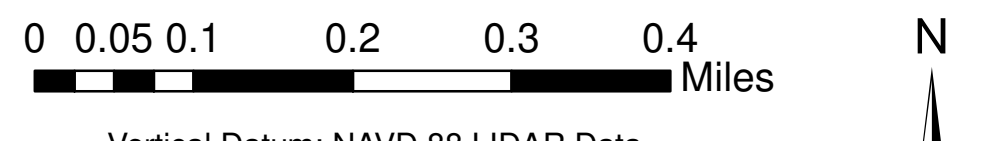

Firm Registration Number F-761